

# BOXKEL OPTIMO POCKET DOOR

by Saheco

Poligono Industrial Foradada - 08580 - Sant Quirze de Besora (Barcelona)  
 Telf. 34-93.852.92.23  
 Export. Telf. 34-93.852.96.15  
 e-mail: saheco@saheco.com - web: www.saheco.com

MADE IN E.U.



OPTIMO  
Installation video



MARCH 2023

038060820

CODE: 99692111, 99692112, 99692113, 99692114, 99692115  
 99692116, 99692117, 99692118, 99692119, 99692120

## LIST OF CONTENTS

u		2 no.
t		2 no.
s	 DIN 7505 B 5X25	8 no.
r		2 no.
p		1 no.
w		2 no.
v		2 no.
x		2 no.
y	 DIN 7505 A 3.5X30	2 no.
z		1 no.

## OPTIONAL SOFTCLOSE

CODE: 99692127

FIXINGS INCLUDED	
 T1 N°6 (x10)	 T2 DIN 7505-B 4x40 (x2)
 T3 DIN 7981 3,5x9,5 (x22)	 T4 DIN 7505 5,5x20 (x2)
 T5 DIN 7981 3,5x22 (x8)	 T6 DIN 7504 N 4,2x22 (x2)

## TOOLS REQUIRED

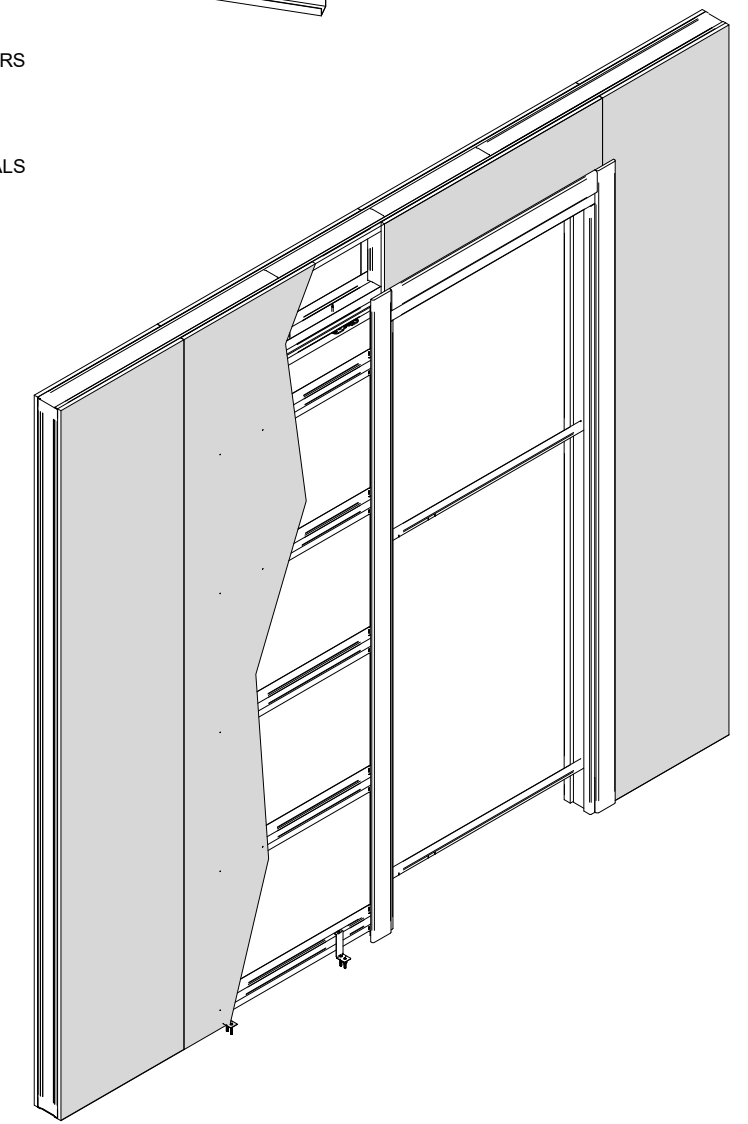
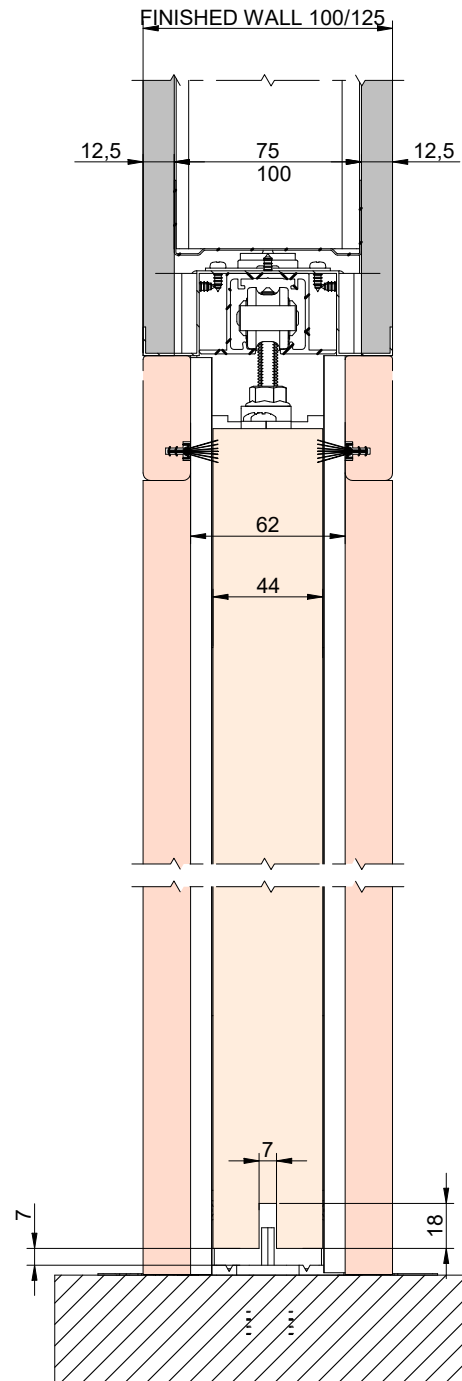
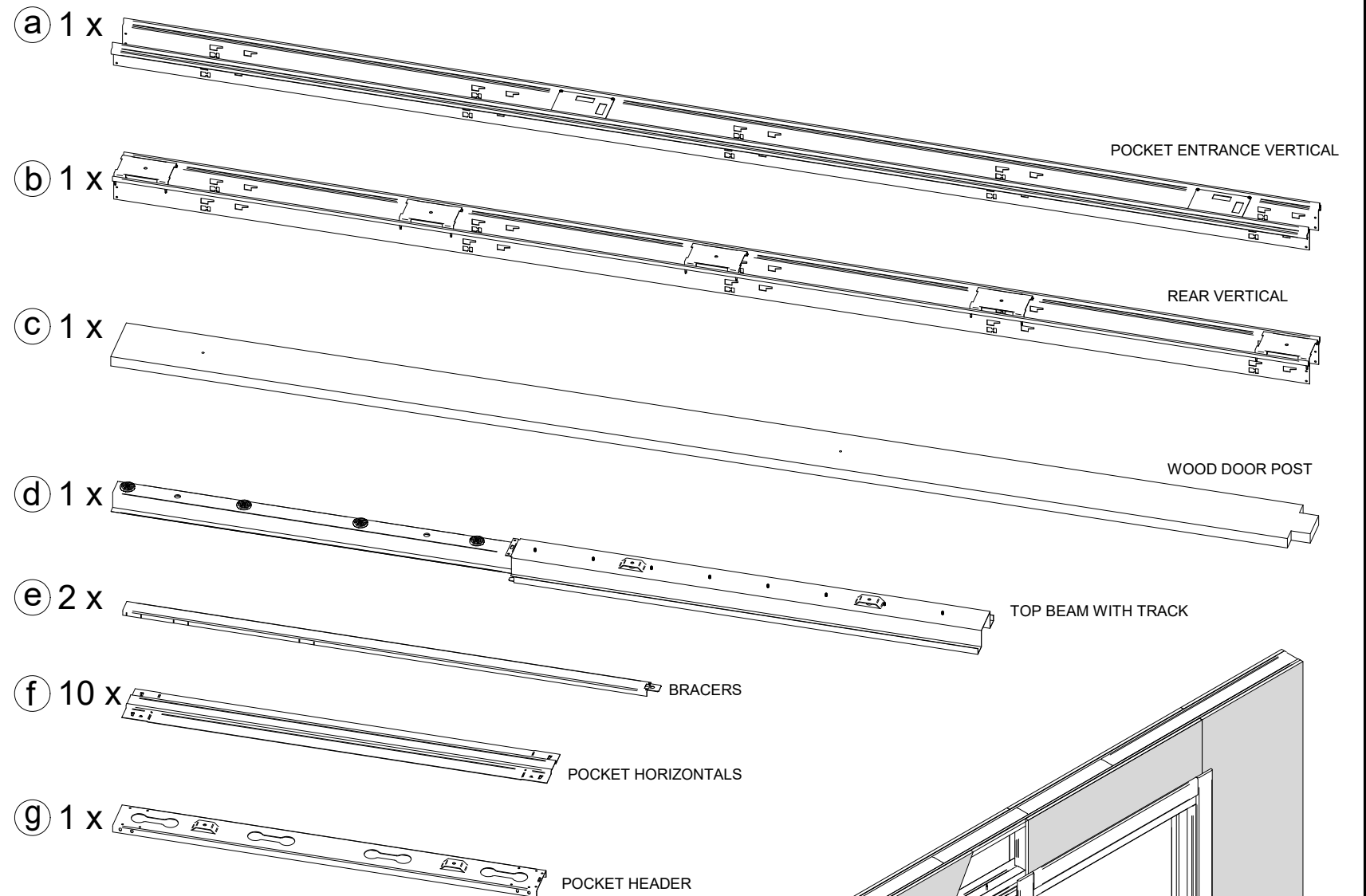
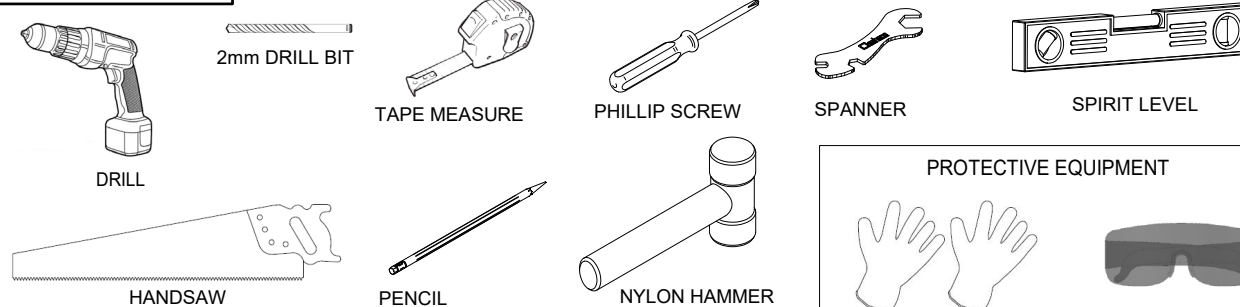

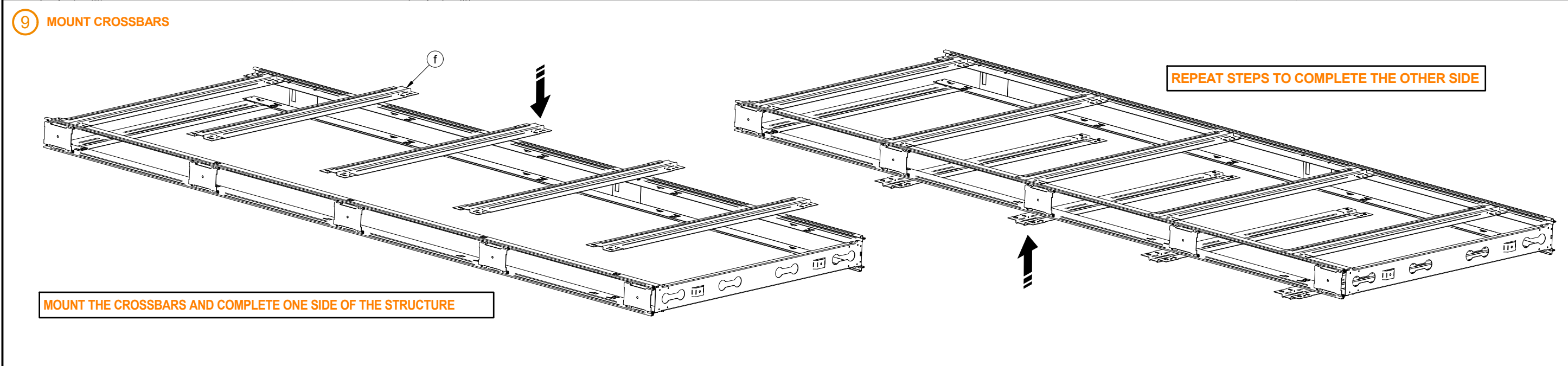
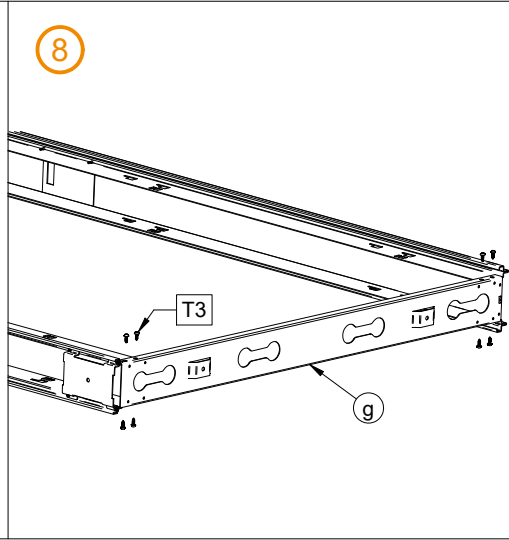
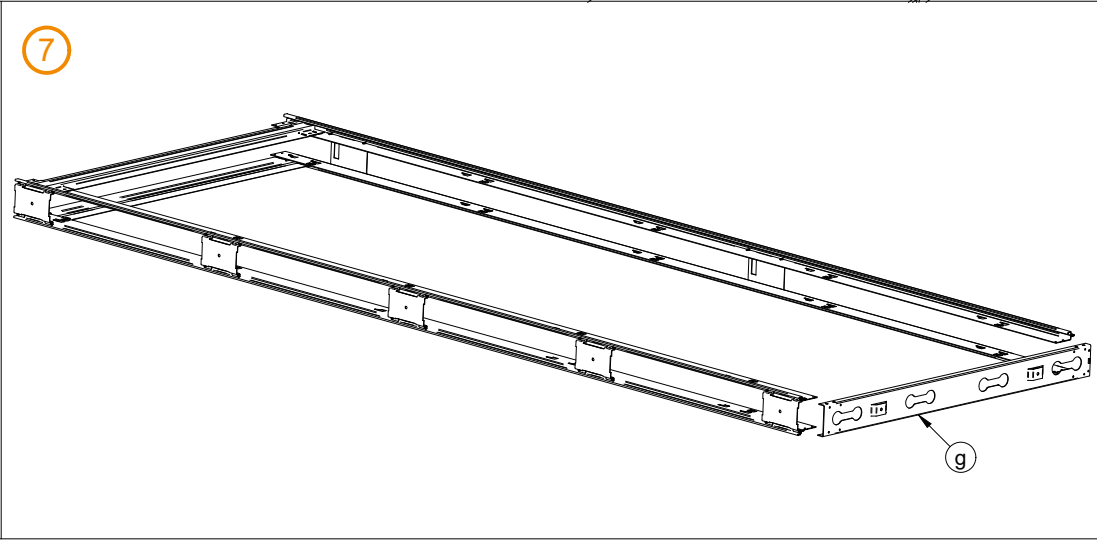
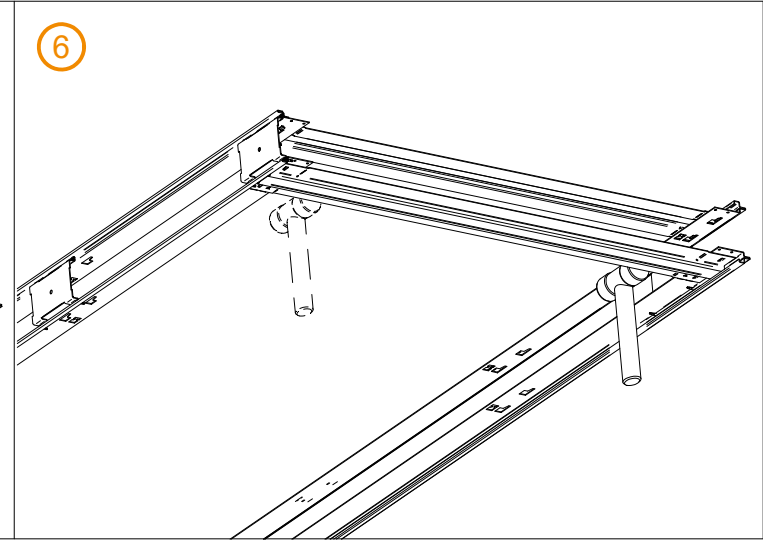
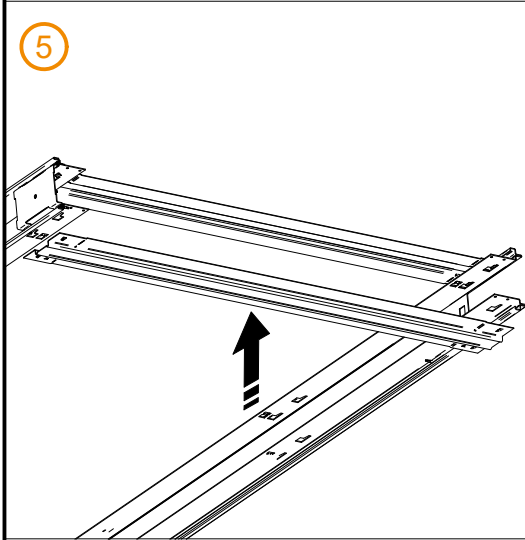
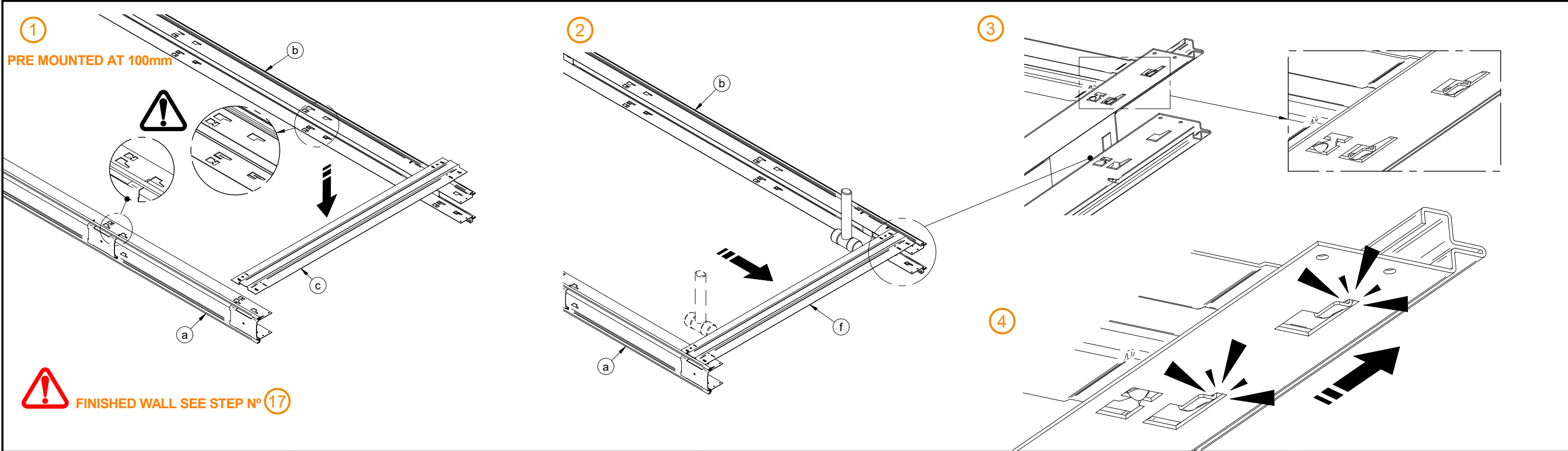

10 STRUCTURE SEPARATOR POSITIONS

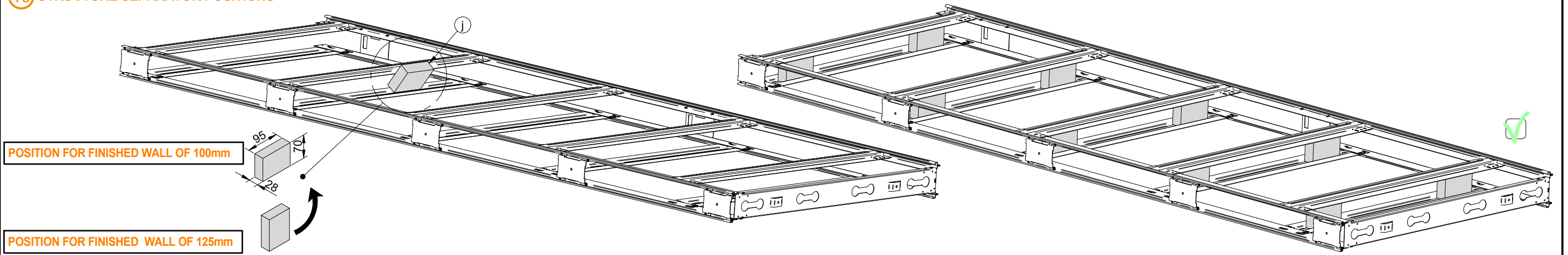

11 INSERT TOP PROFILE

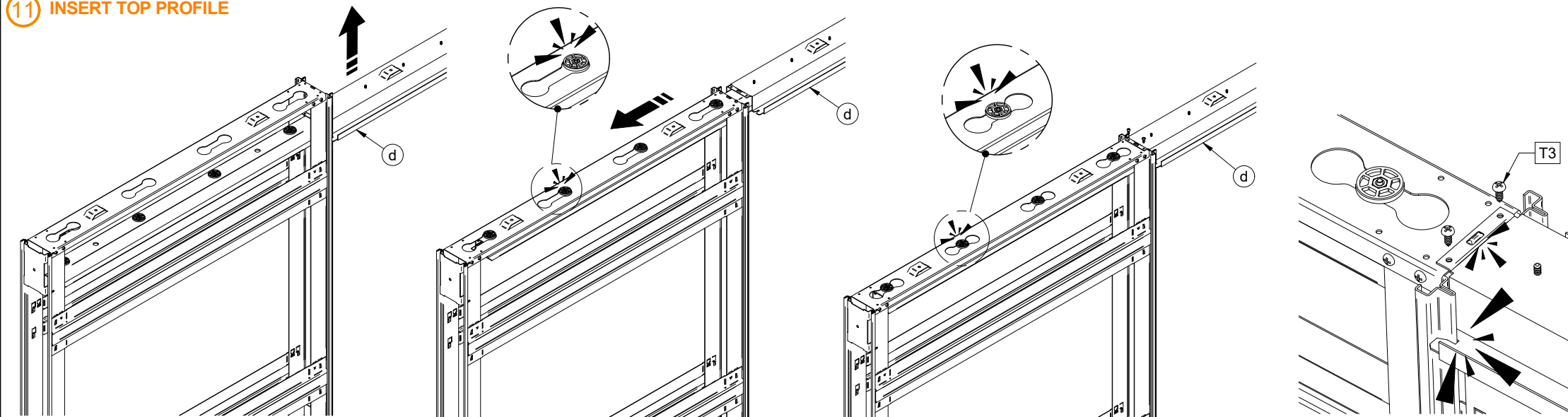

12 INSERT TRACK ON WOODEN VERTICAL

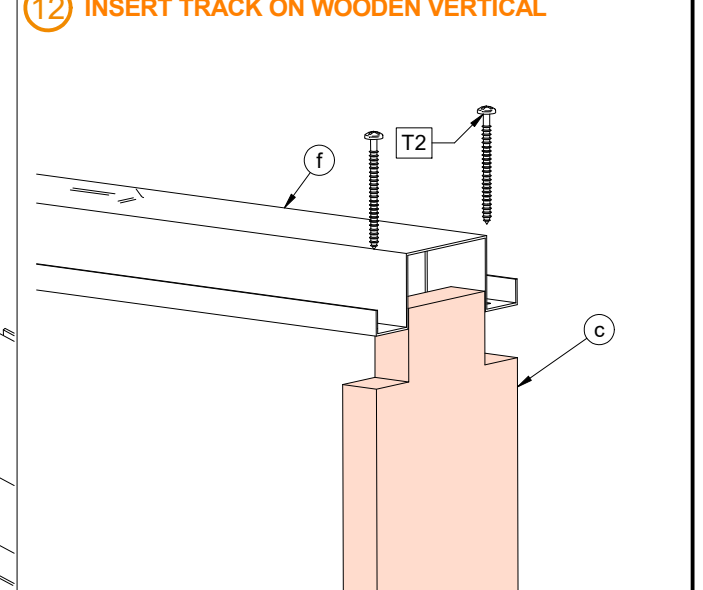

13 REMOVE GUIDE PROFILE

 IN THE CASE OF REMOVING COMPONENTS

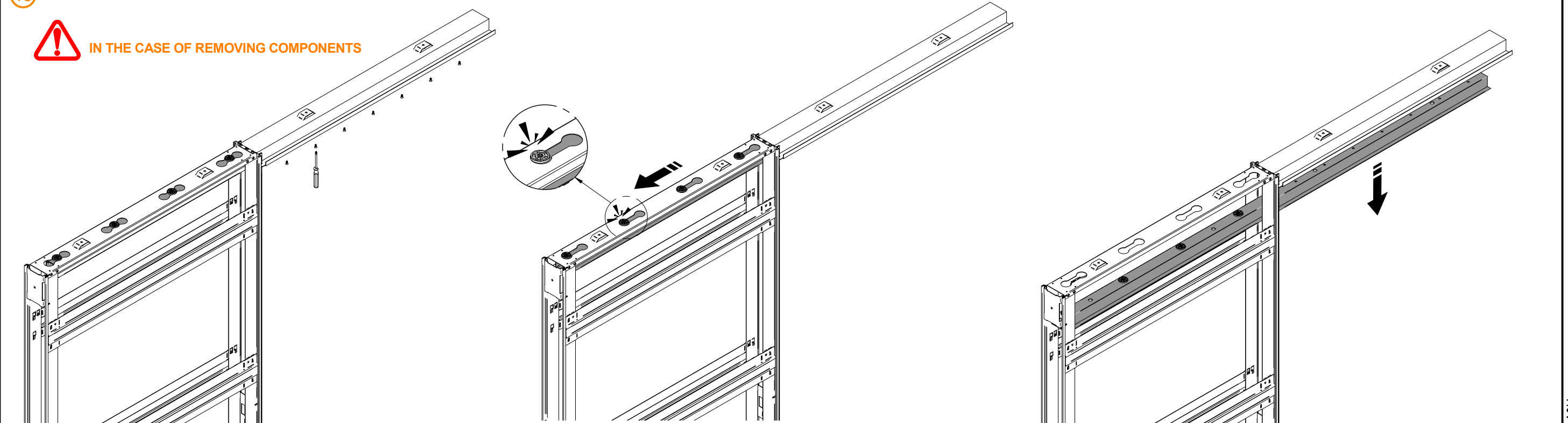

14 INSERT THE CROSSBARS

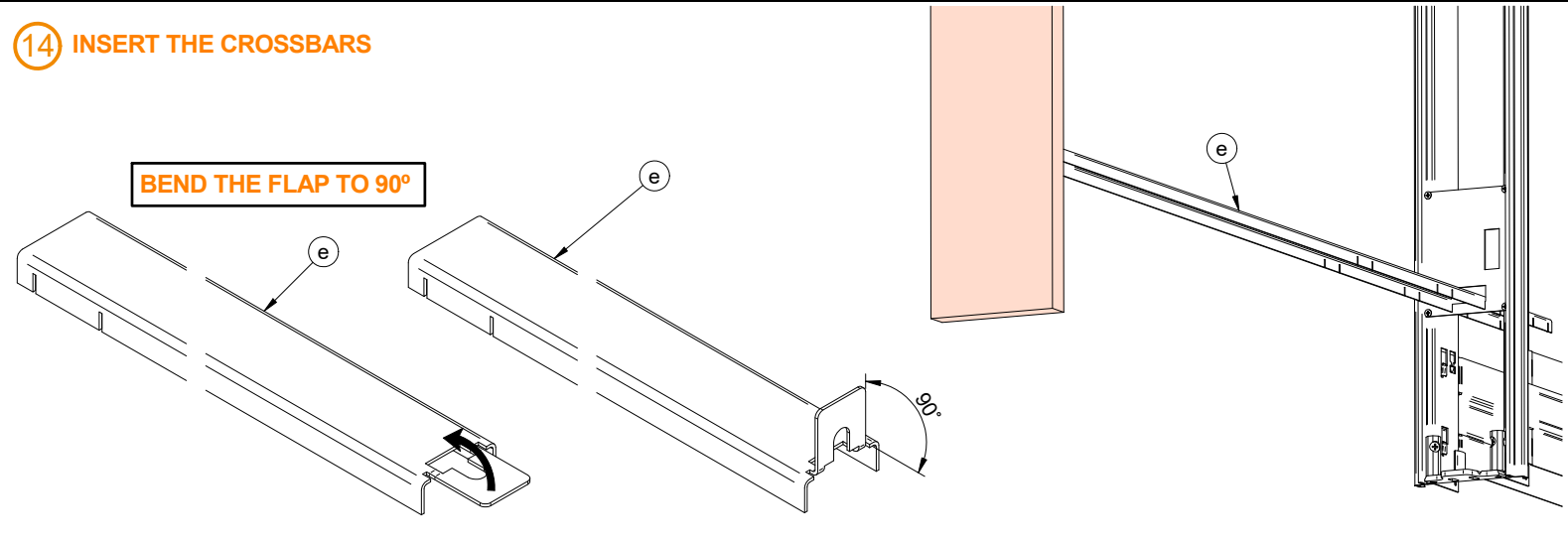

15

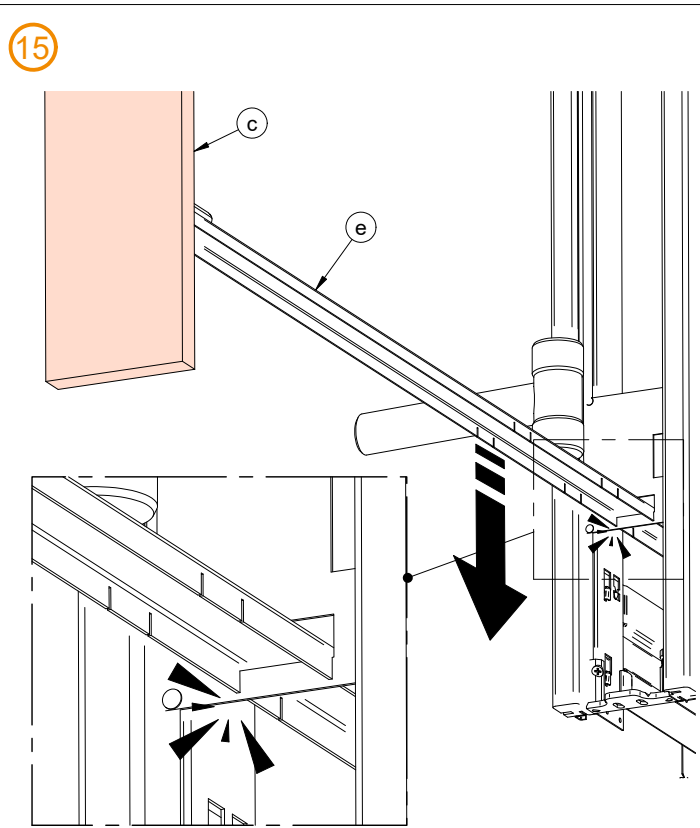

16

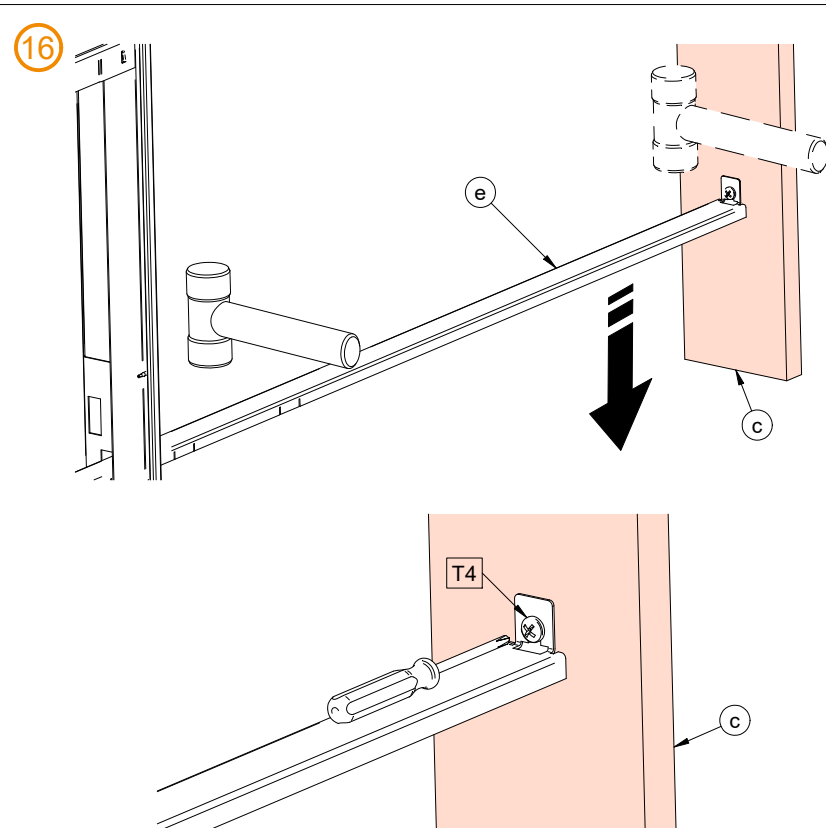

17 MOUNT BOTTOM GUIDE TO THE STRUCTURE

FOR FINISHED WALL OF 100mm

FOR FINISHED WALL OF 125mm

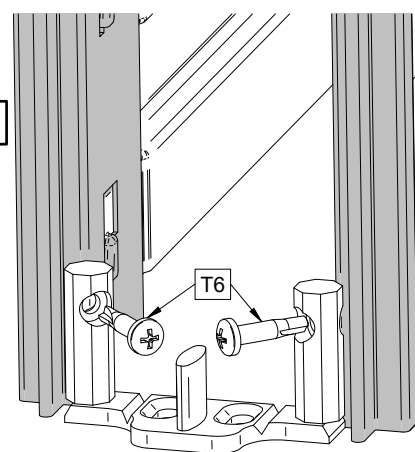
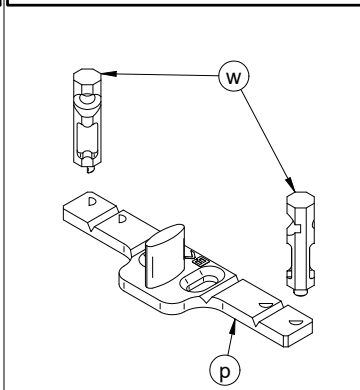
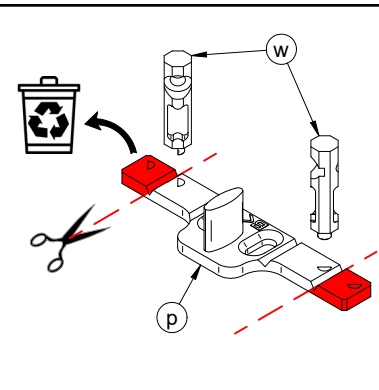

OPTIONAL FLOOR MOUNT ONLY FOR FINISHED WALL OF 125mm

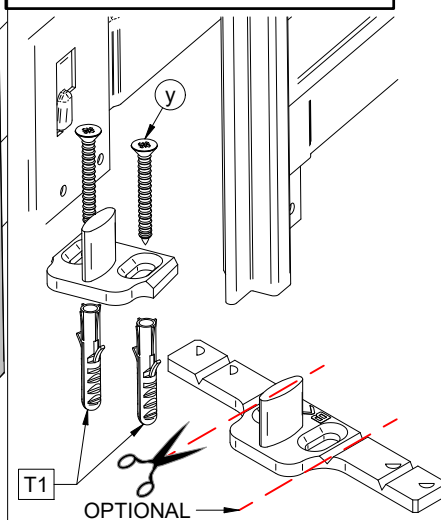

17 CONVERT 100 FINISHED WALL TO 125mm

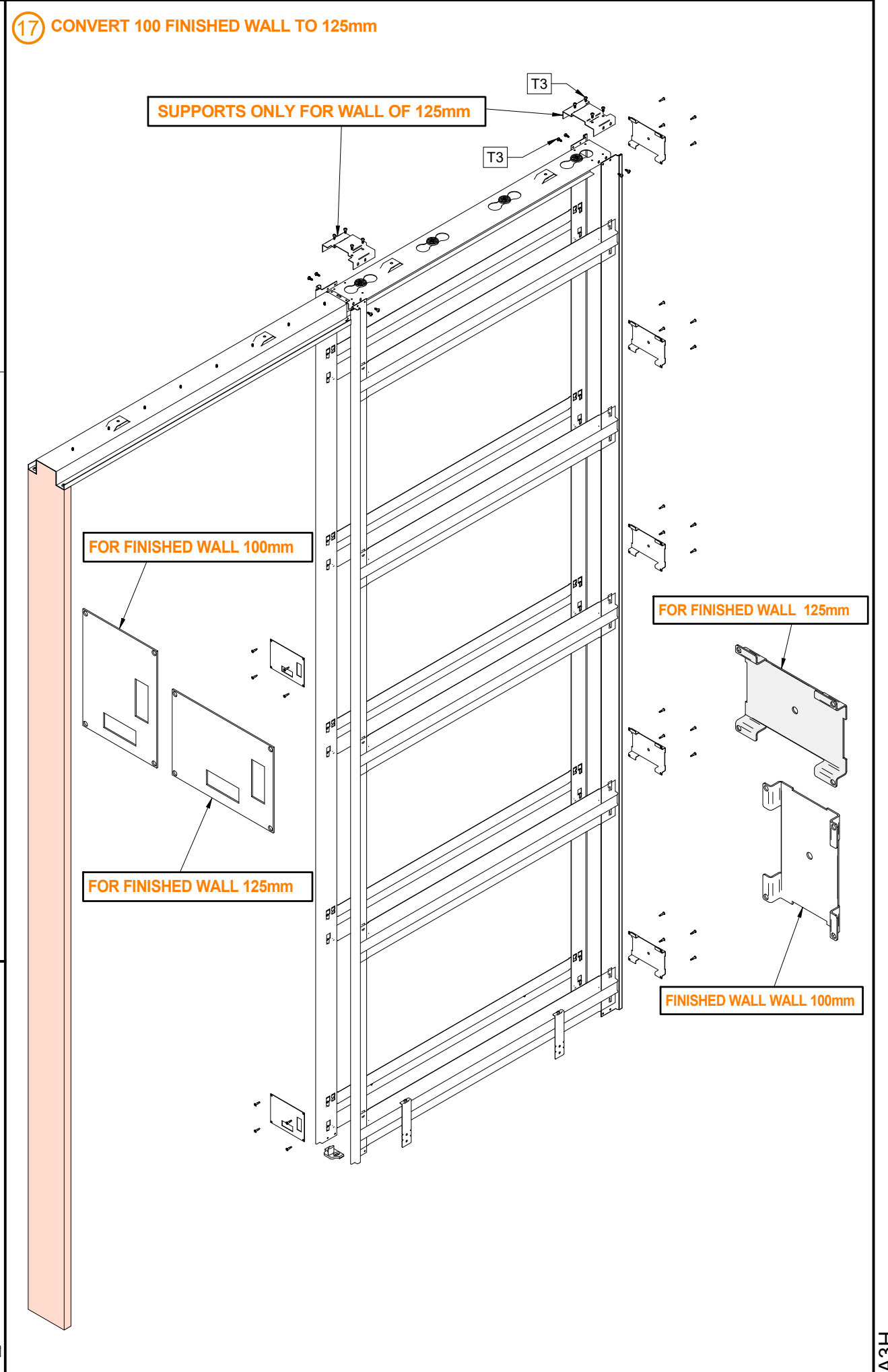

18

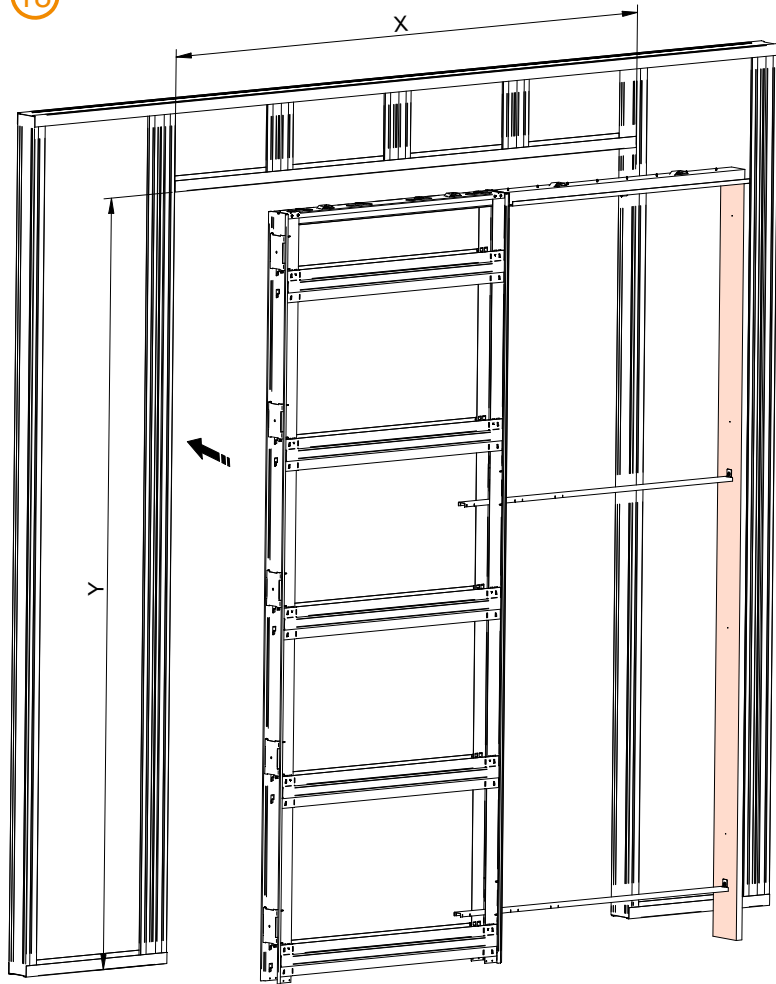

### ROUGH OPENING

CODE	WIDTH (X)	HEIGHT
99692111	1284	2127
99692112	1484	2127
99692113	1684	2127
99692114	1884	2127
99692115	2084	2127
99692116	1252	2068
99692117	1404	2068
99692118	1556	2068
99692119	1708	2068
99692120	1860	2068

19

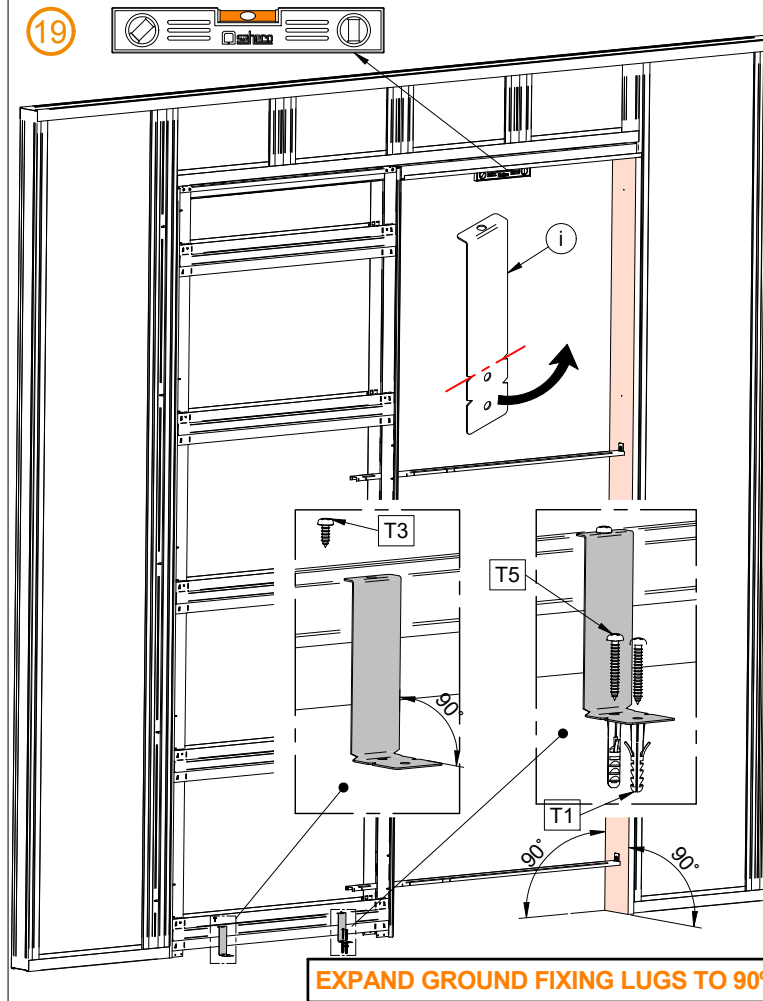

20

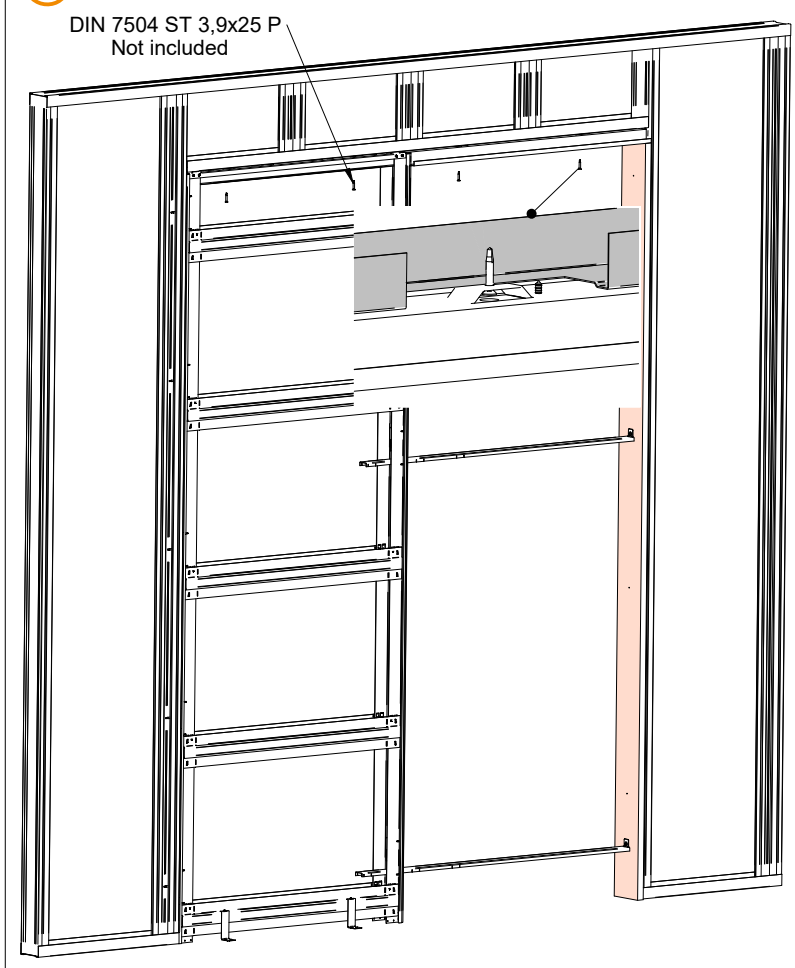

21

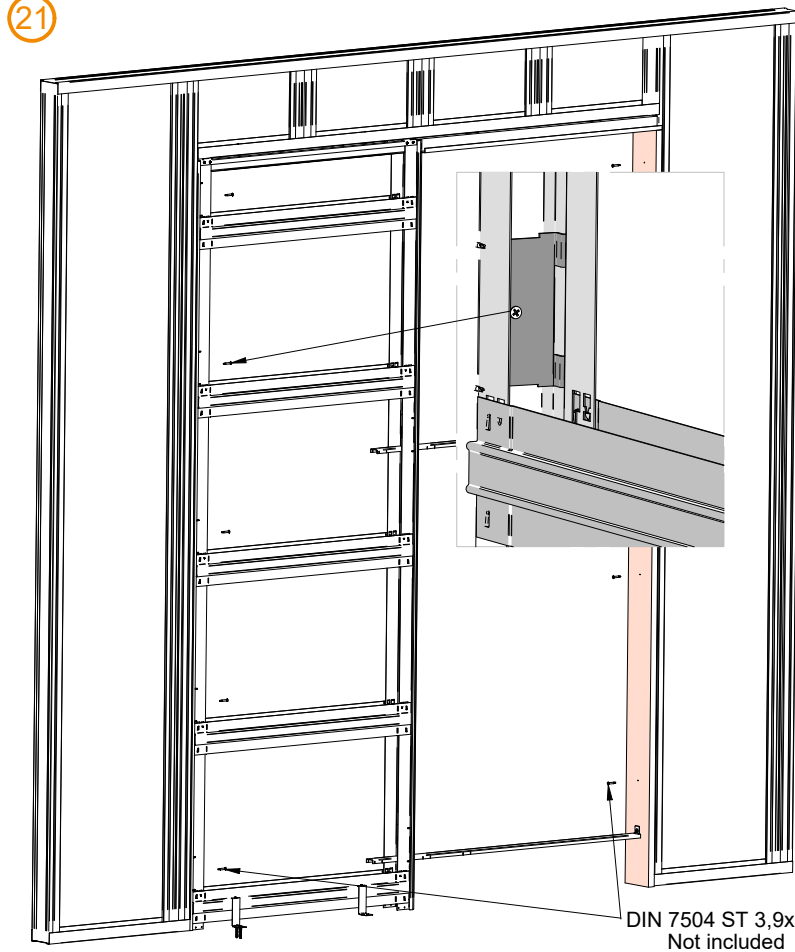

### 22 PLASTERBOARD ASSEMBLY

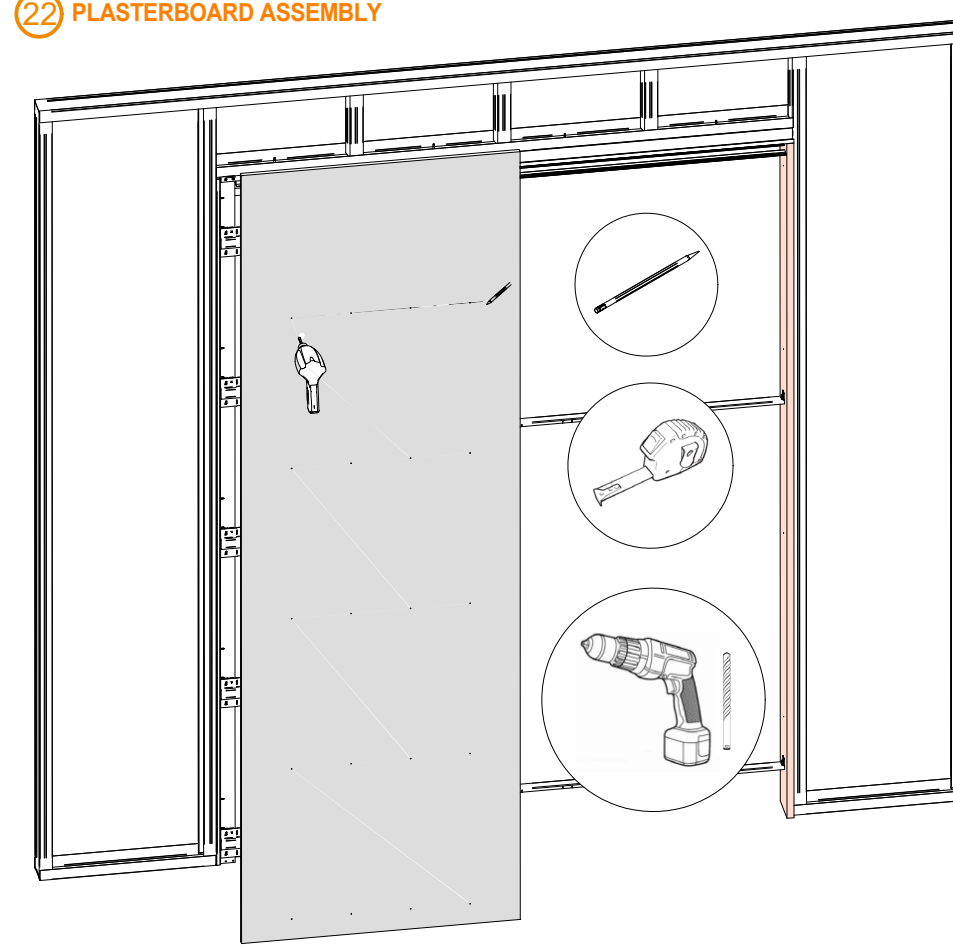

23

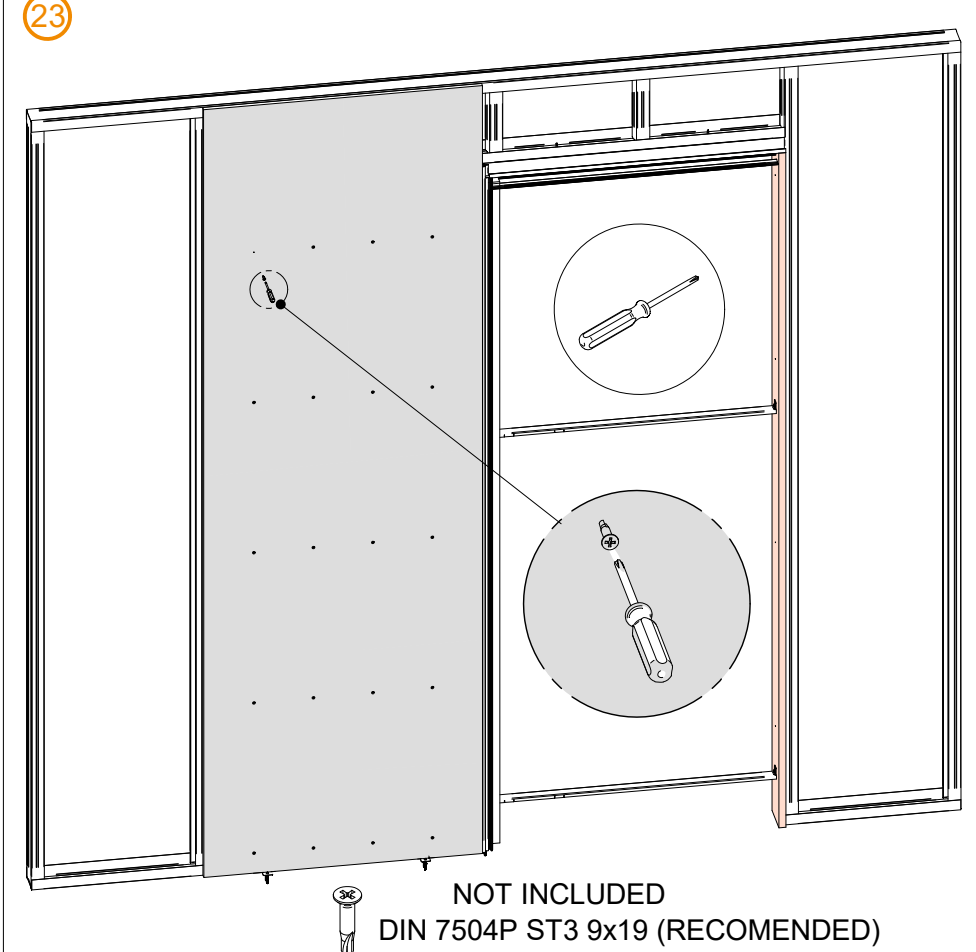

# ASSEMBLY OF DOOR COMPONENTS

## STANDARD STOP

①

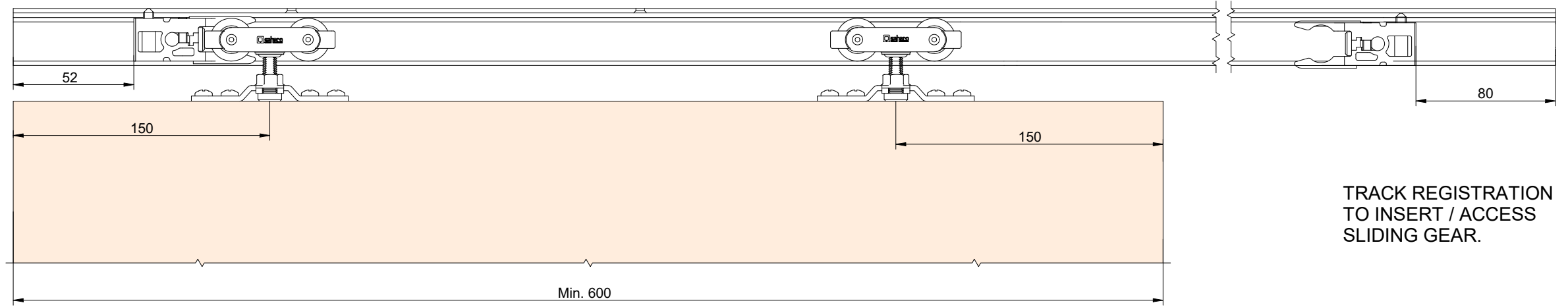

## ② ASSEMBLY COMPONENTS

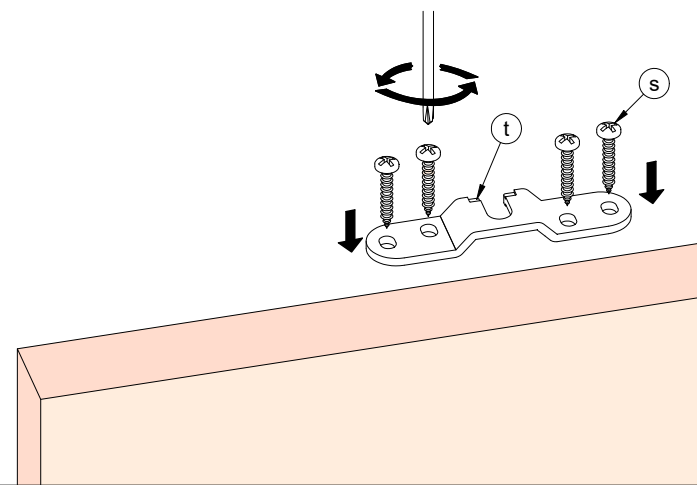

③

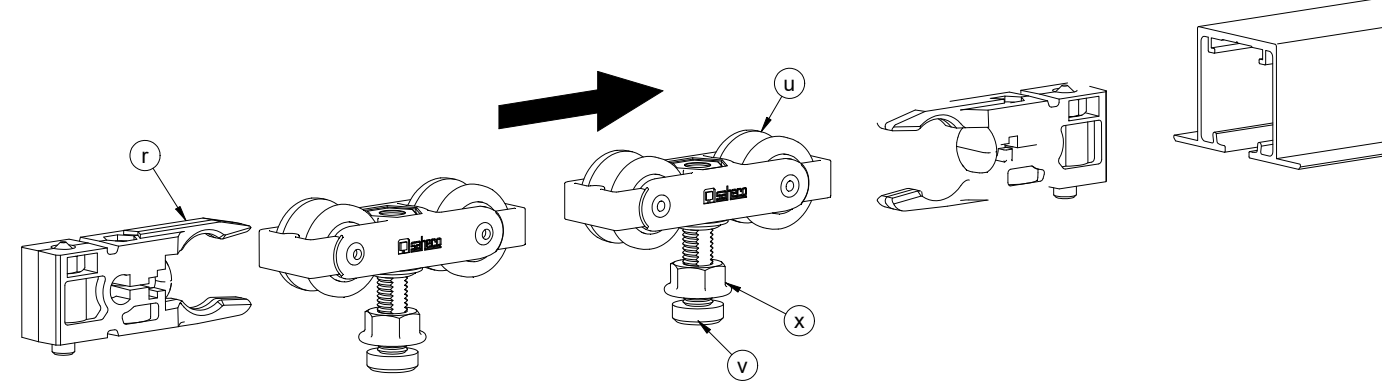

## ④ TRACK REGISTRATION TO CHANGE COMPONENTS

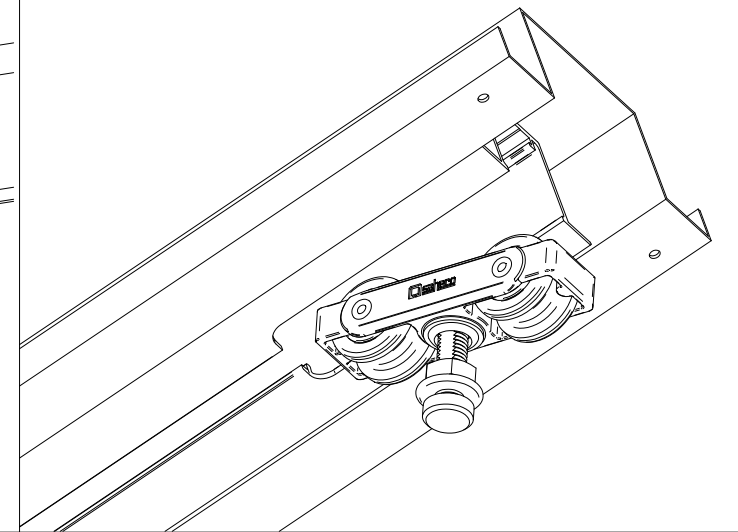

⑤

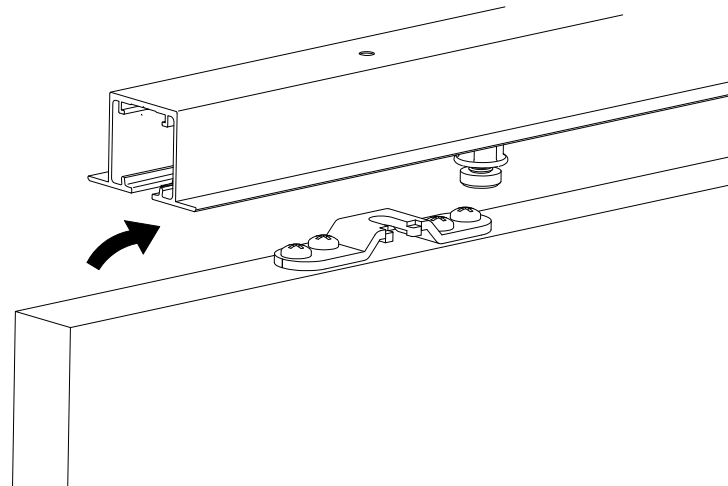

⑥

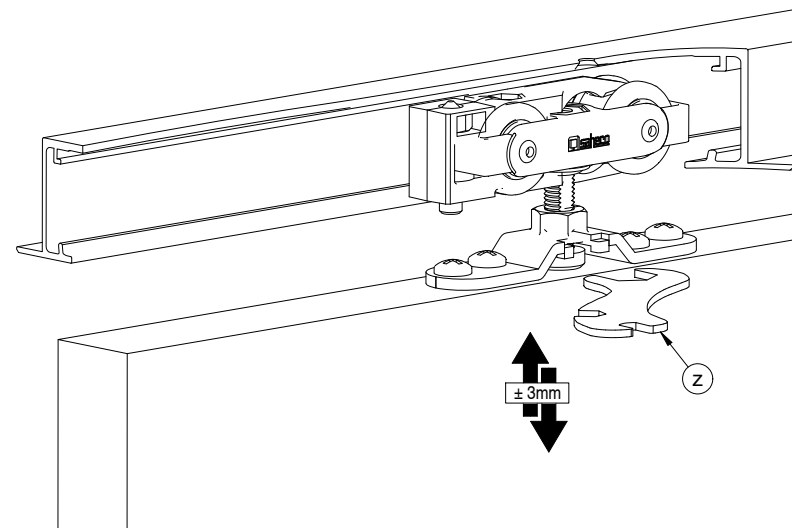

⑦

