

Montageanleitung
Hochschrankauszug "Dispensa Swing-x"

Assembly Instruction
Larder pull-out "Dispensa Swing-x"

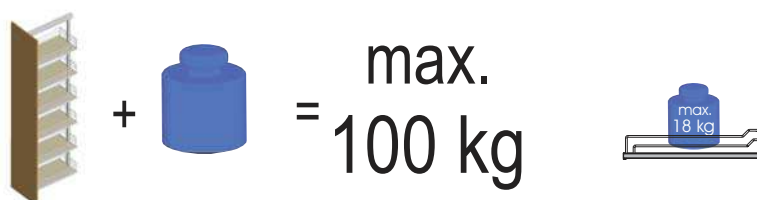

Eigengewicht + Beladung
Empty weight + Load

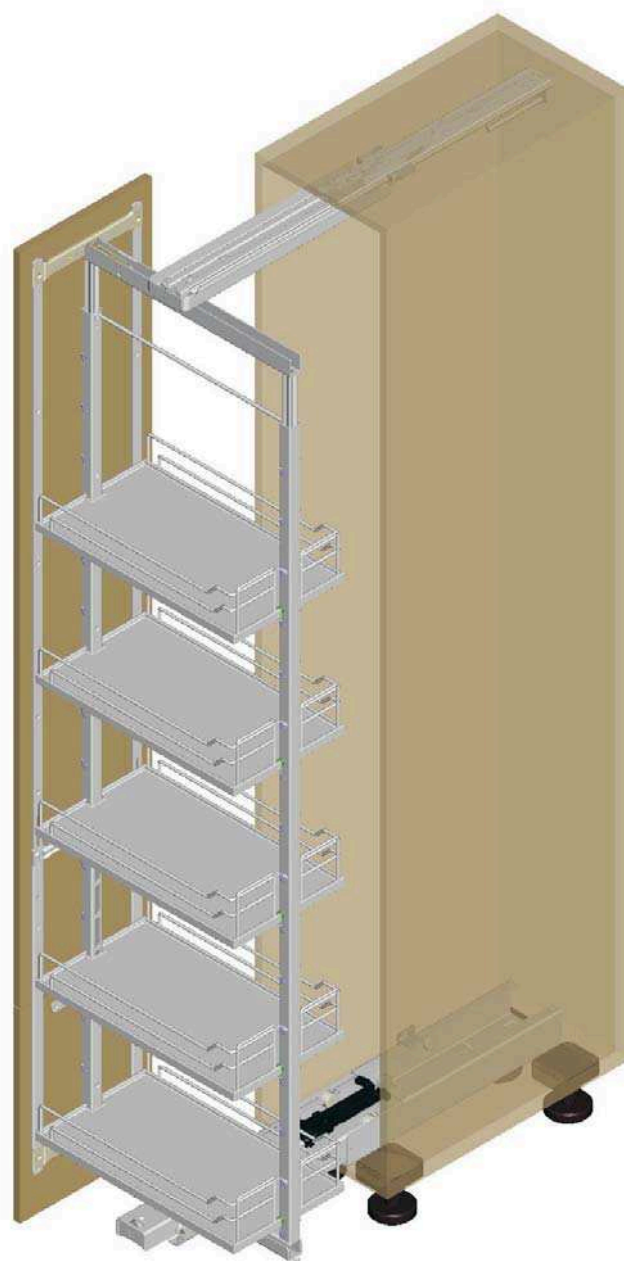

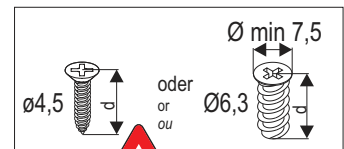
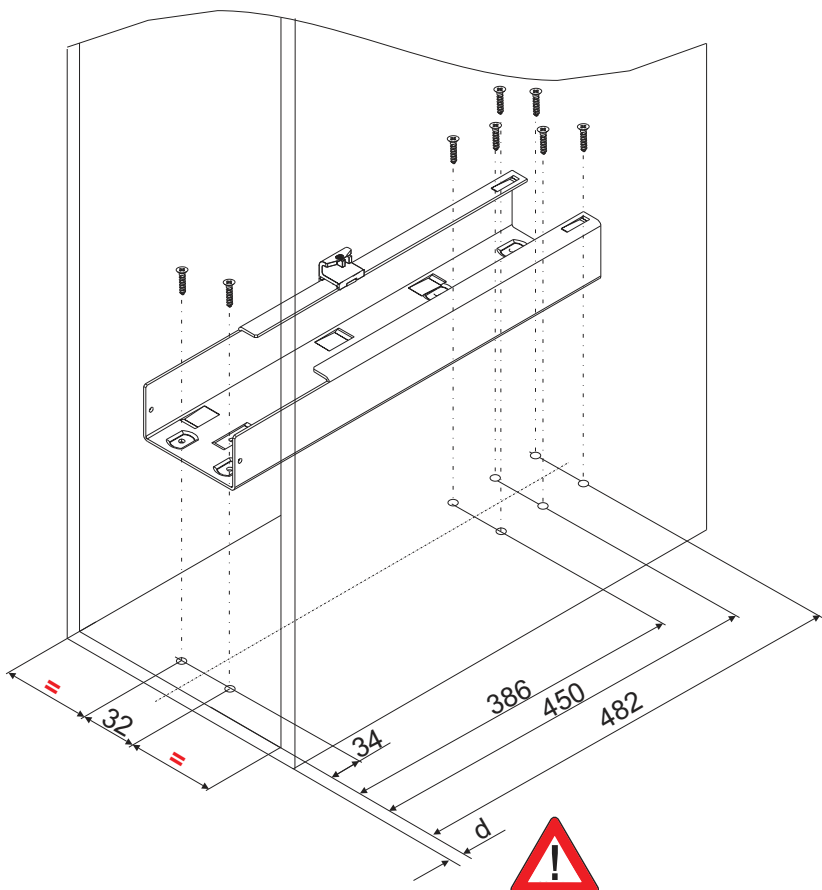
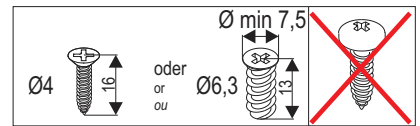
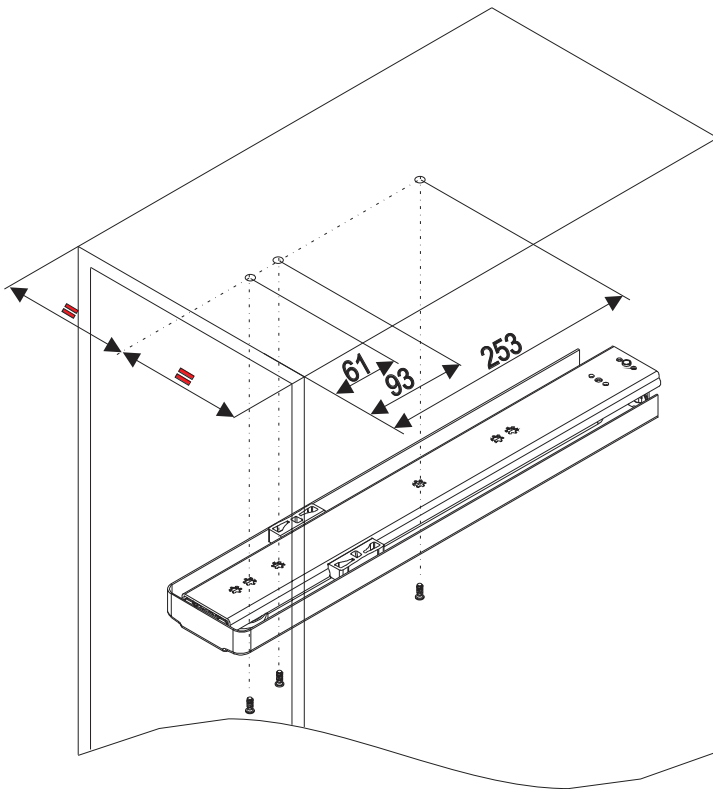
1

2

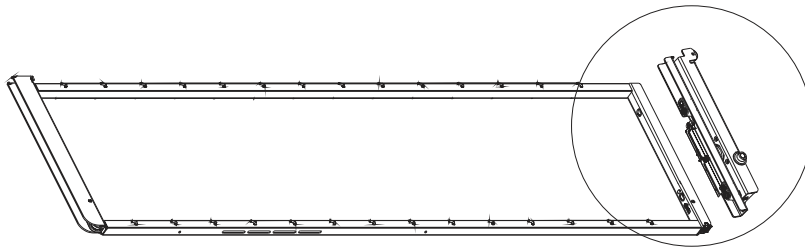

A

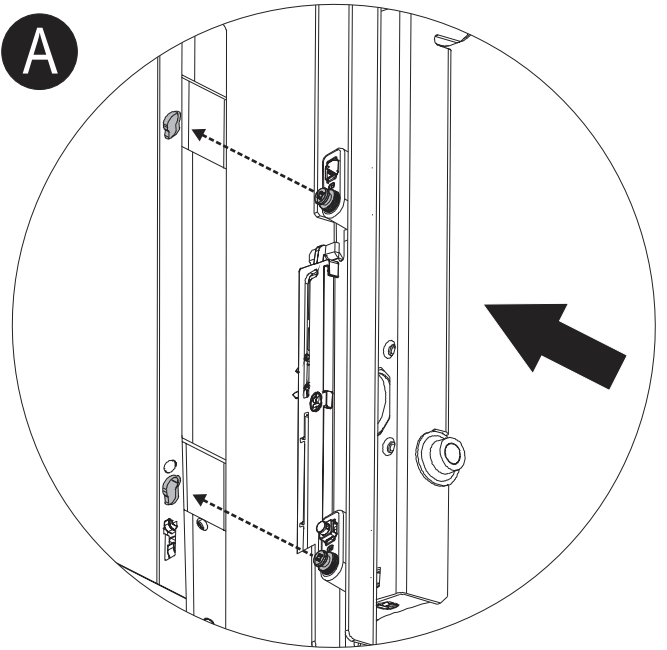

B

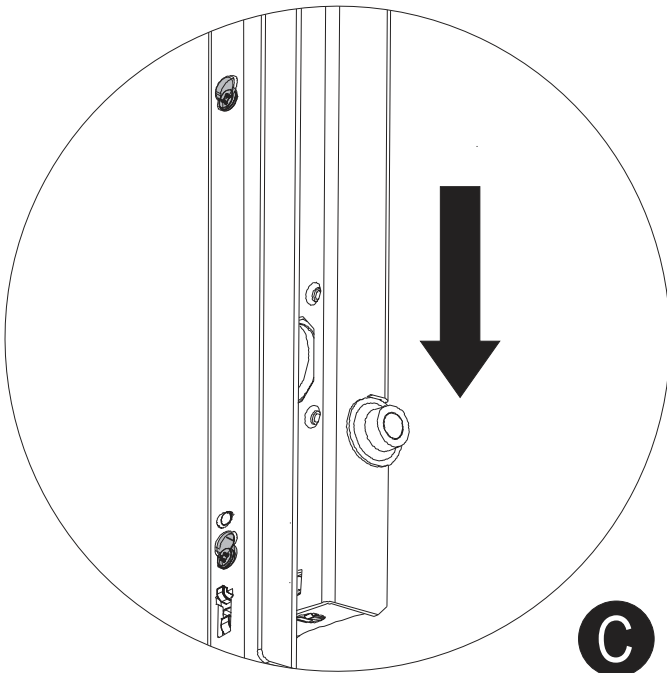

C

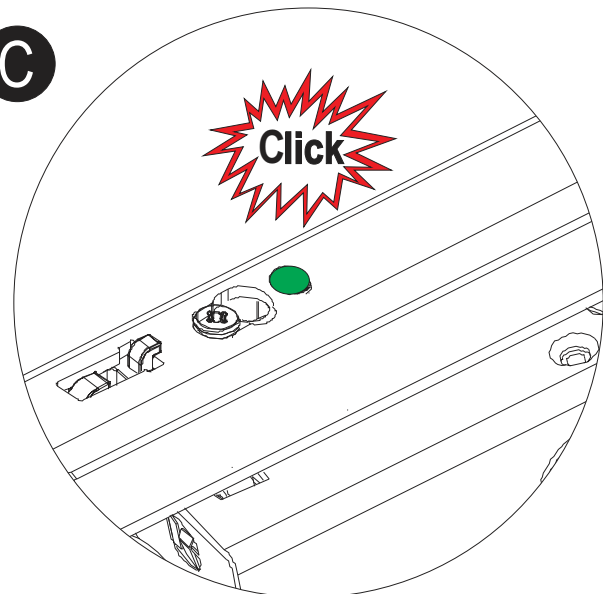

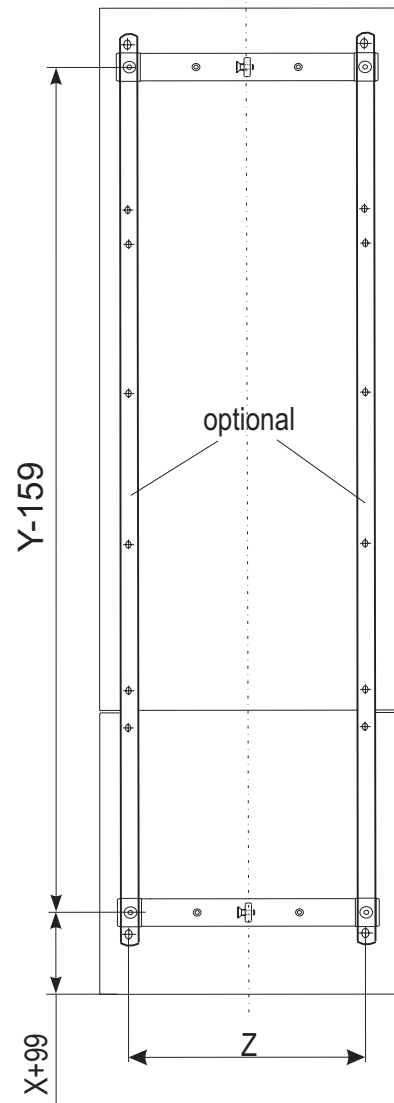
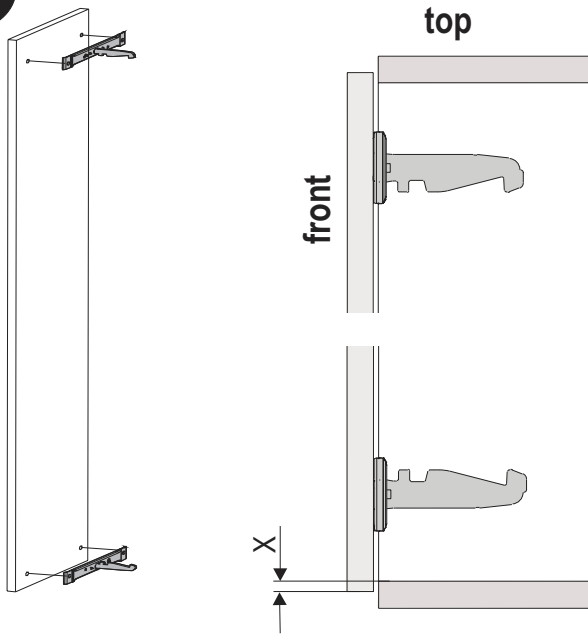
3

5

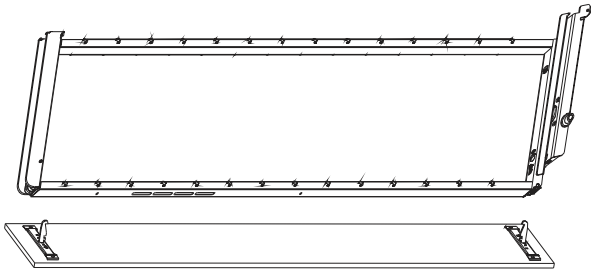

A

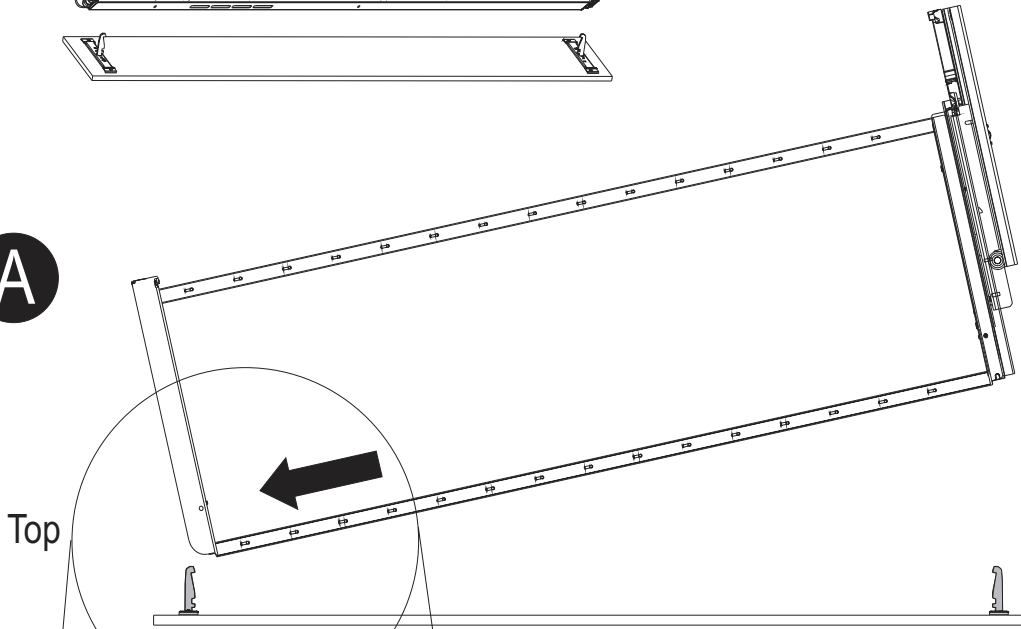

Top

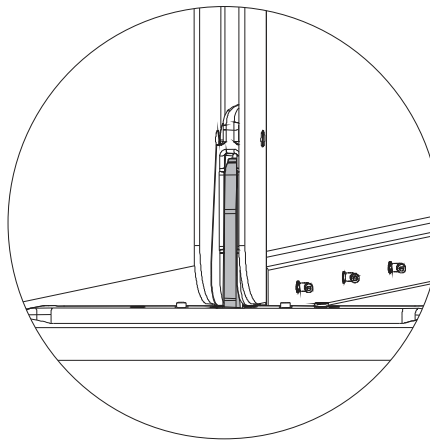
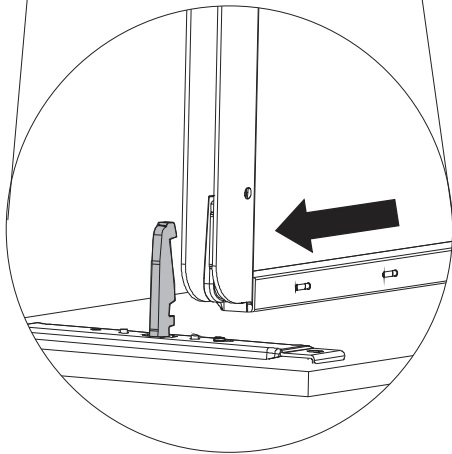

B

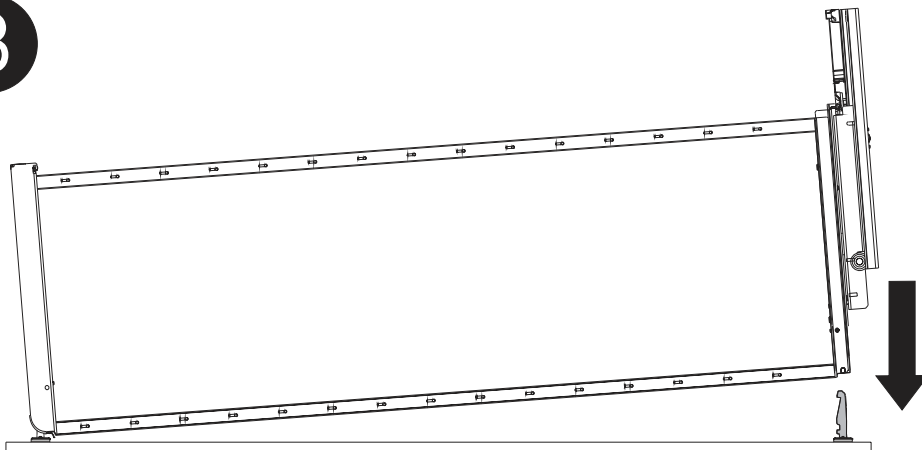

6

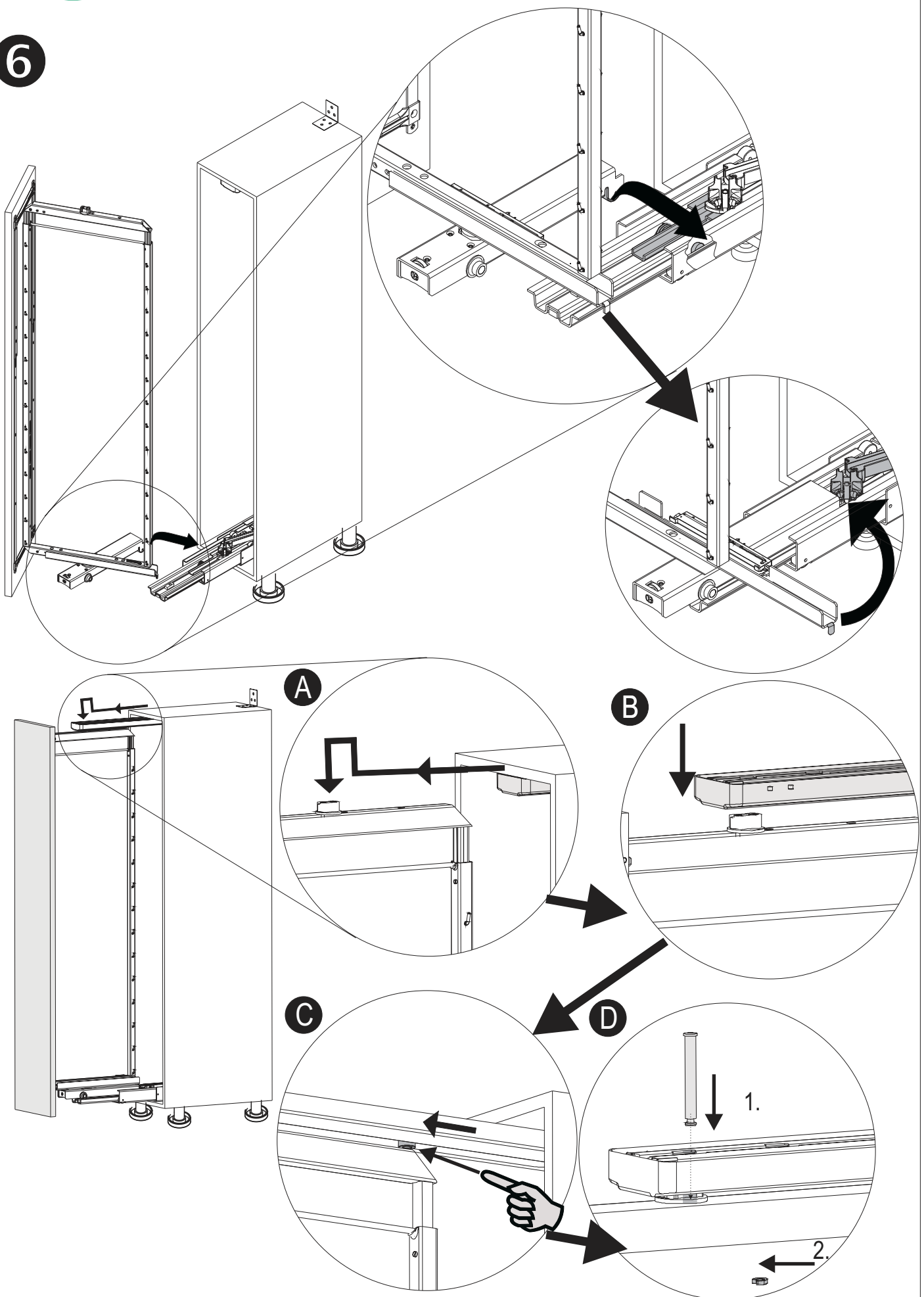

Justieranleitung

Hochschrankauszug "Dispensa Swing-x"



Adjusting Instruction

Larder pull-out "Dispensa Swing-x"

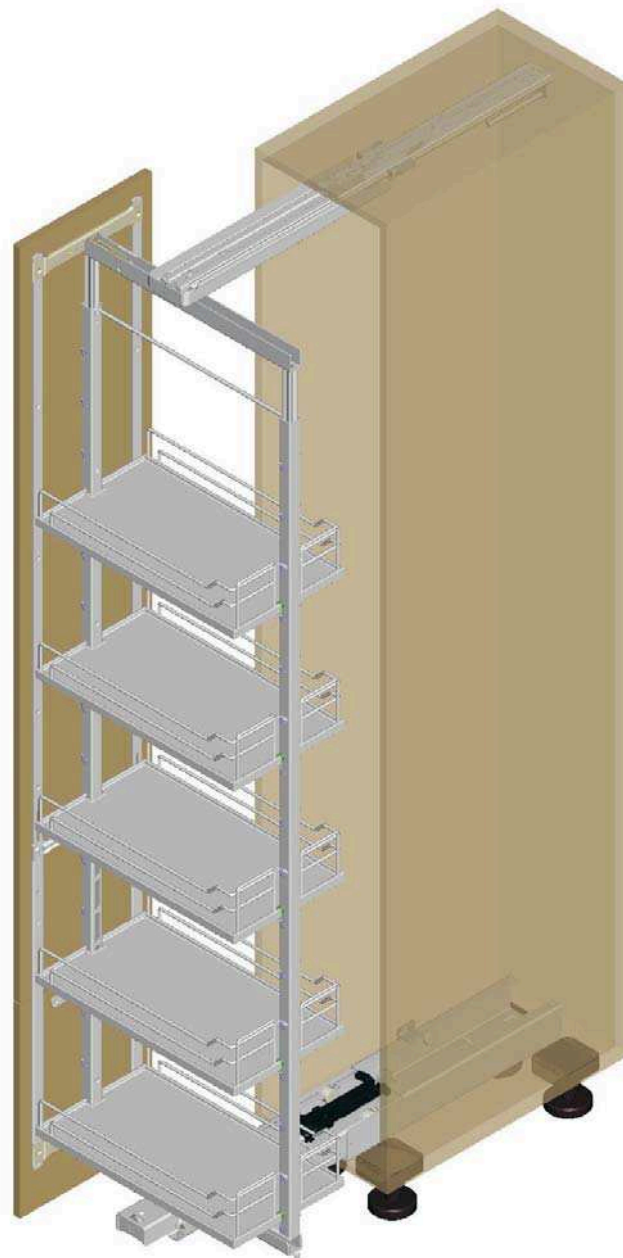

+



= max.
100 kg

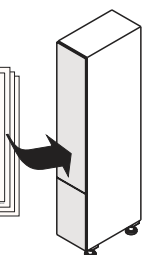

Eigengewicht + Beladung
Empty weight + Load

1

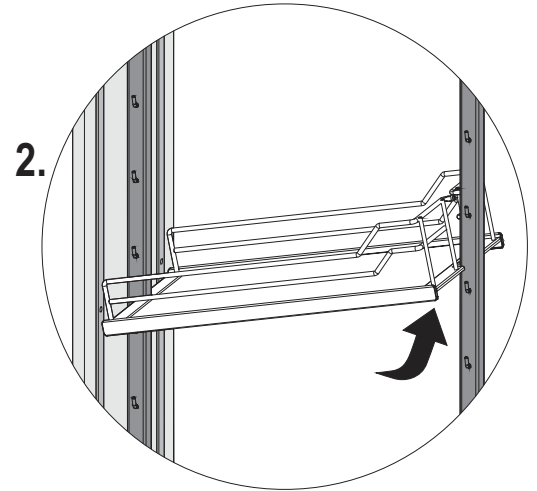
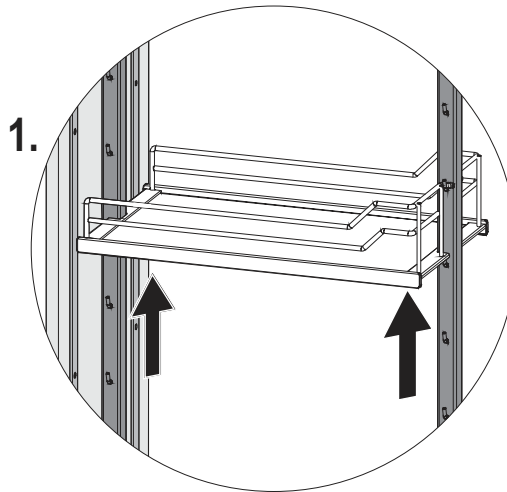
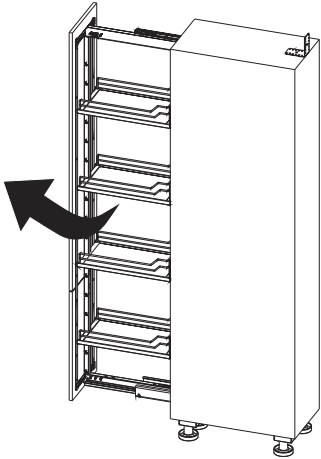
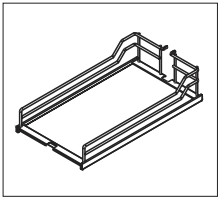

1a

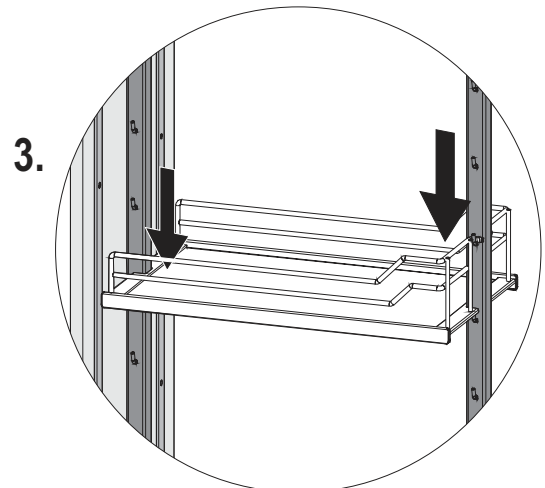
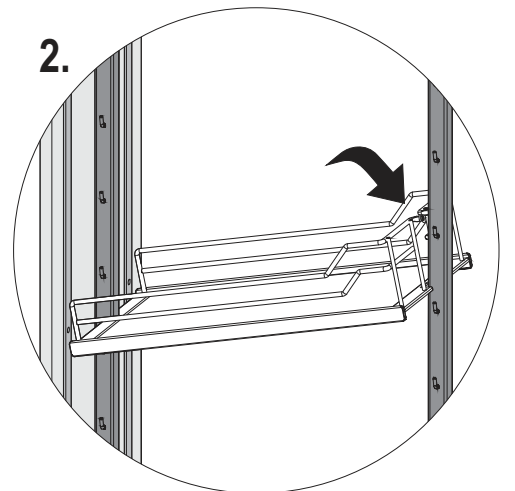
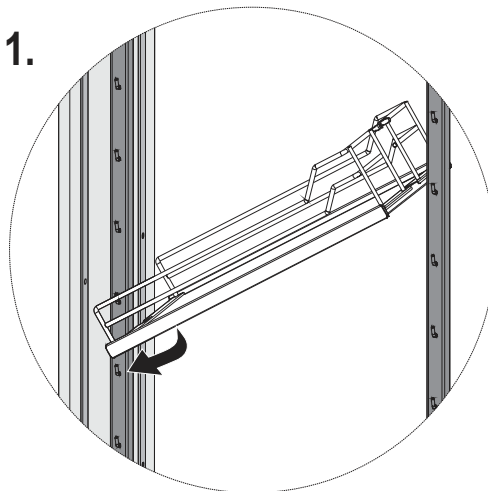
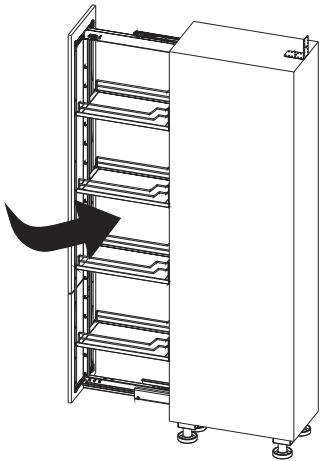

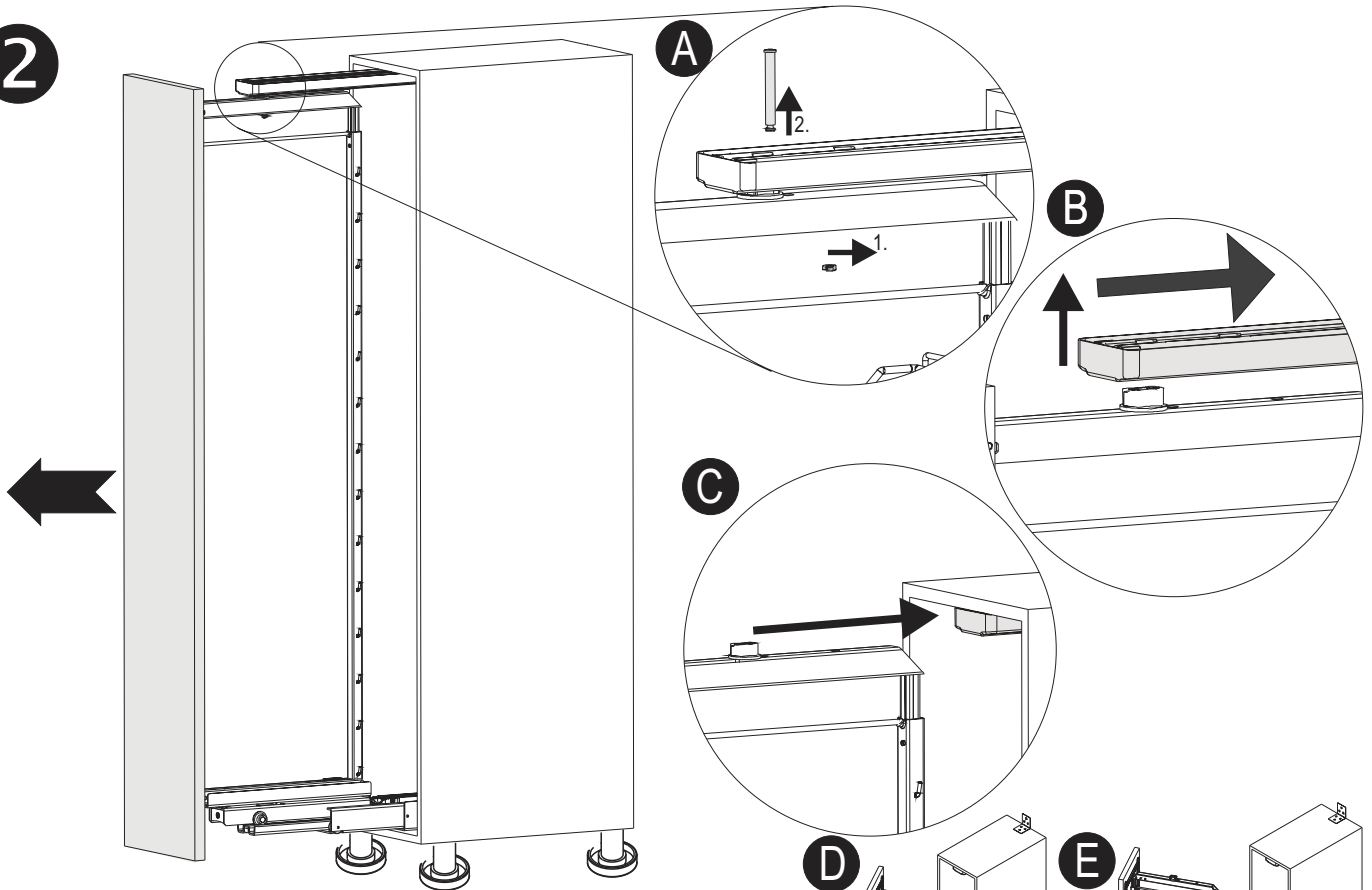
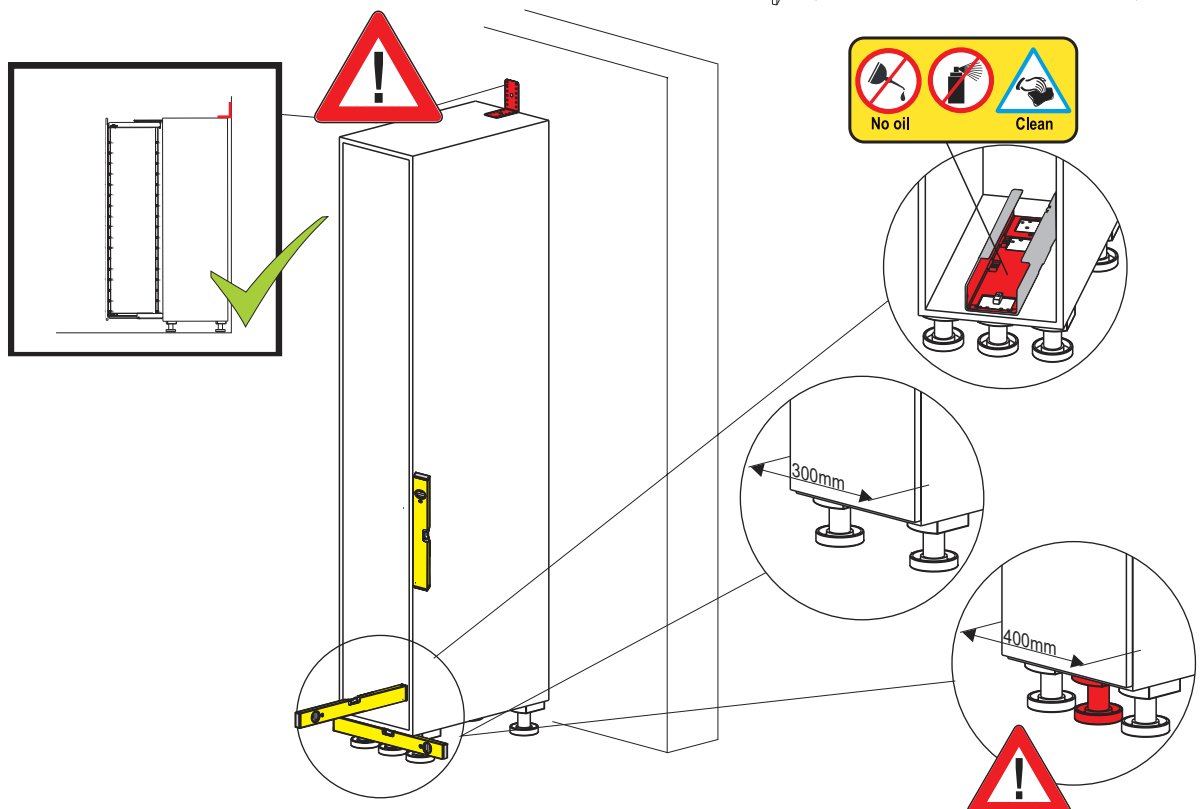
2

3

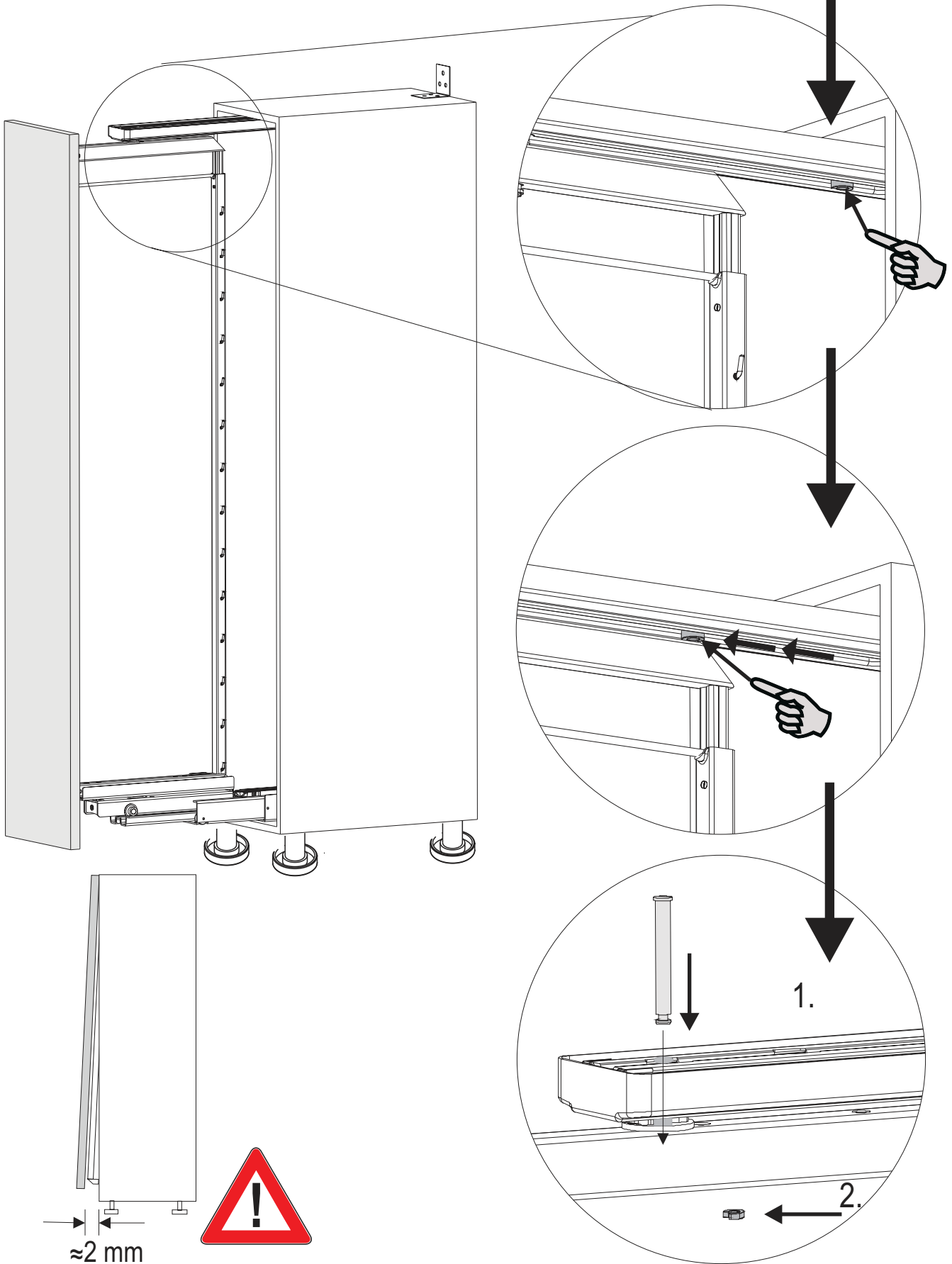
4

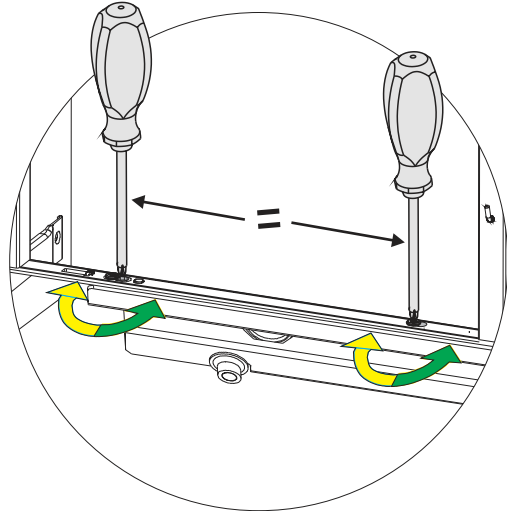
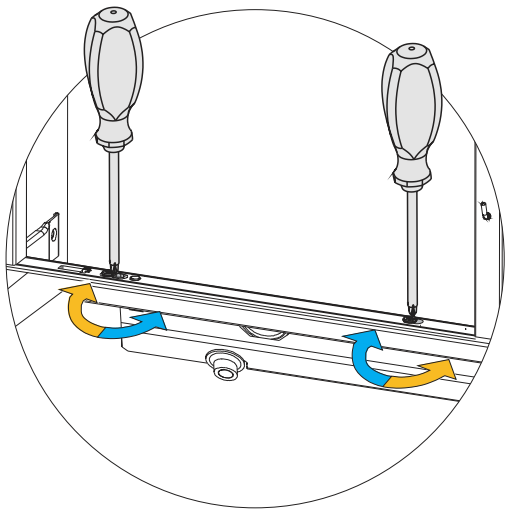
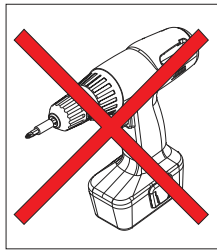
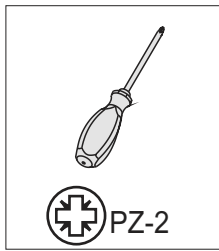
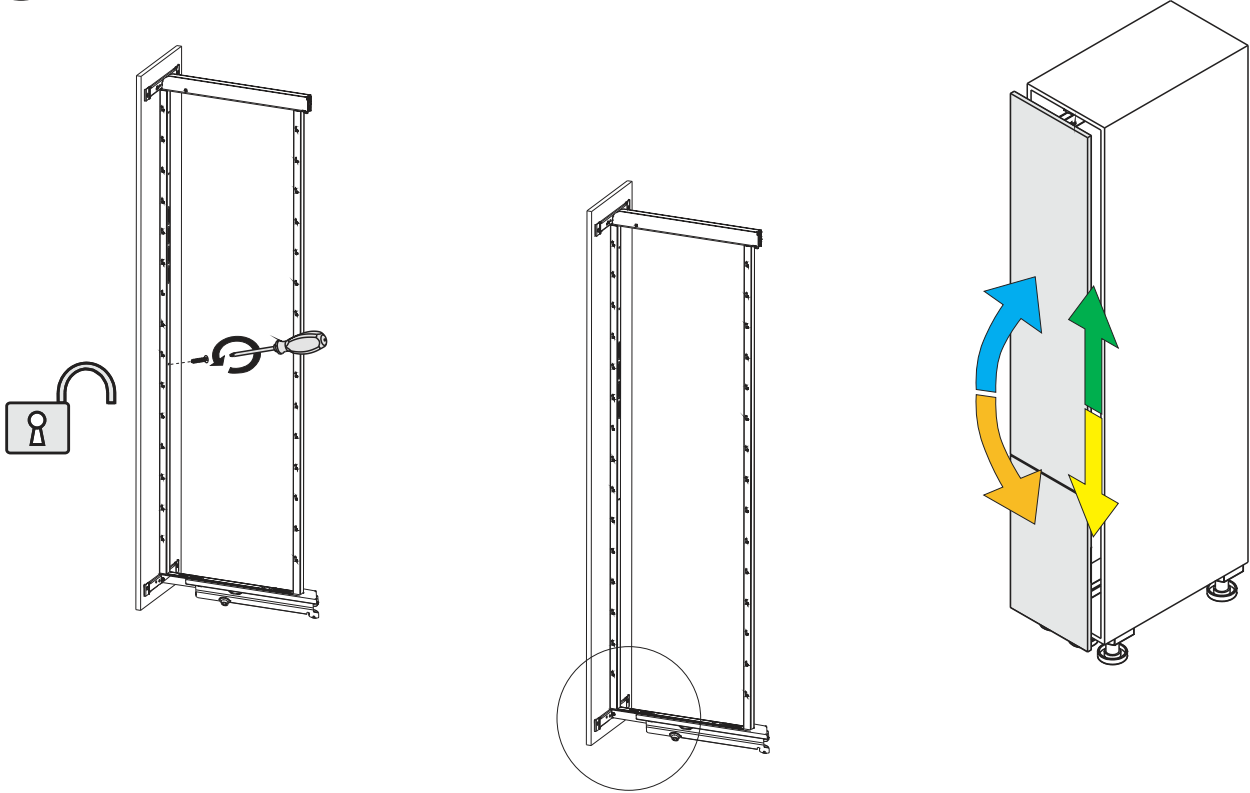

5



6

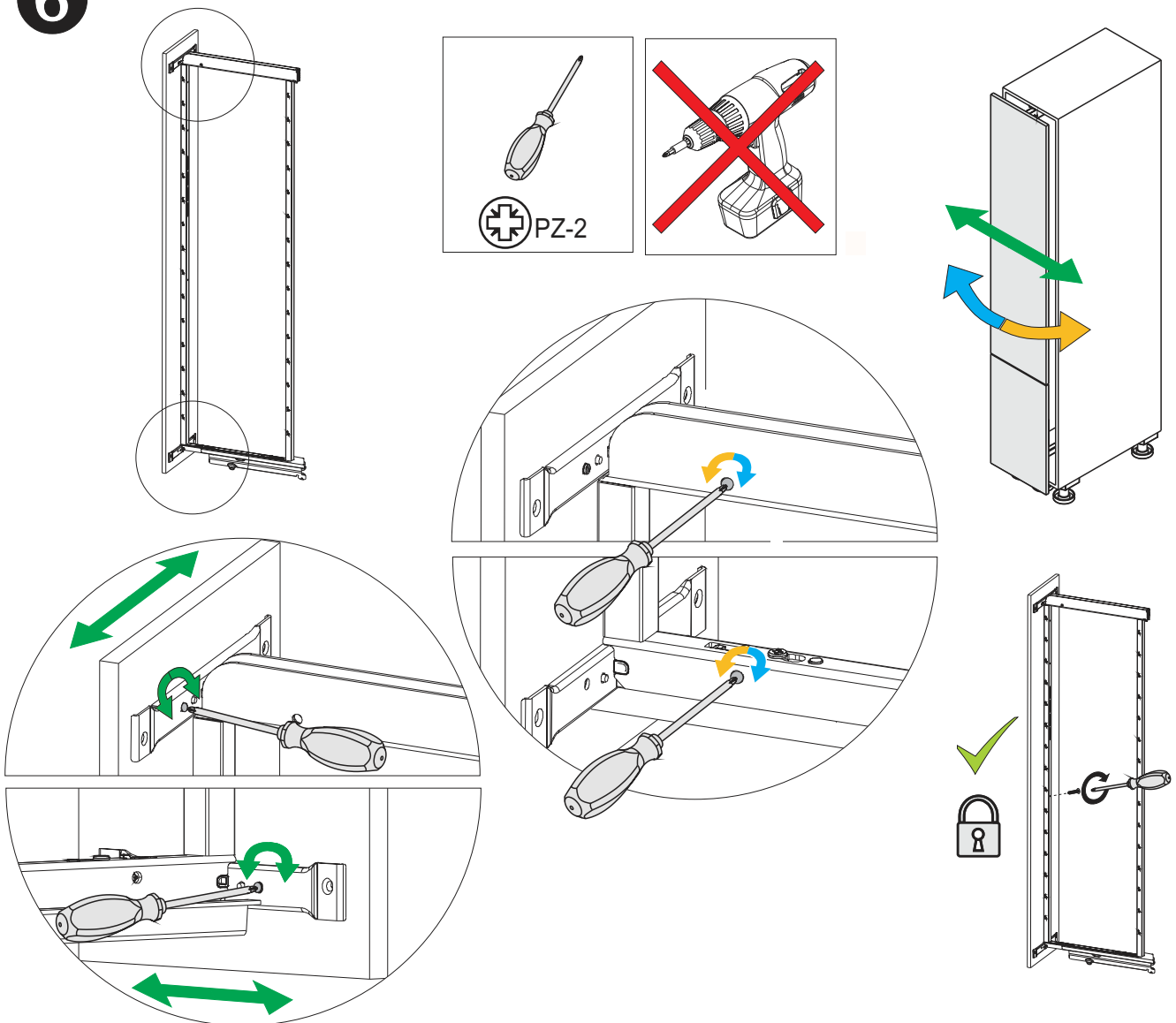

1 Demontage der Front
Disassembling front

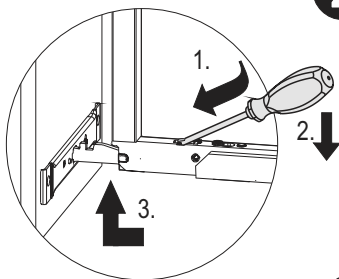
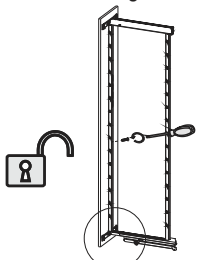

2 Montage der Front
Assembling front

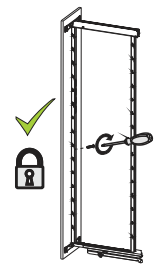
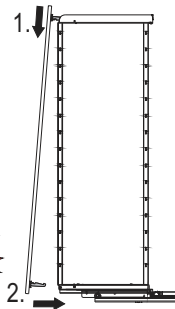

3 Demontage der Schiene
Disassembling runner

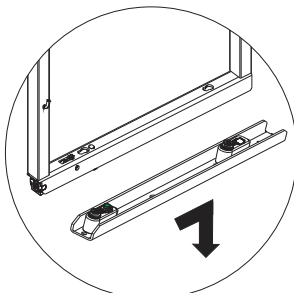
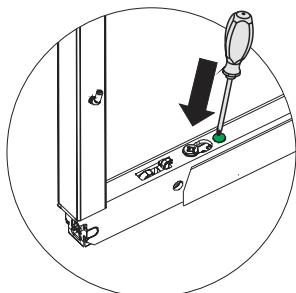

4 Montage der Schiene
Assembling runner

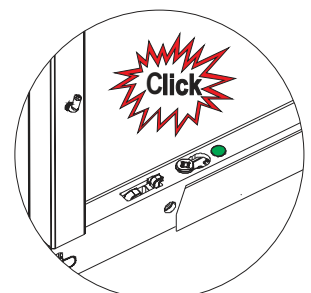
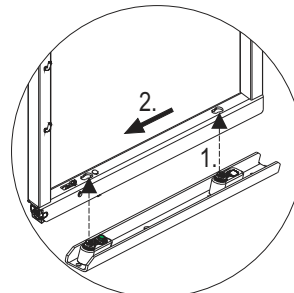

Die technischen Darstellungen und Maßangaben -auch bei Abbildungen und Zeichnungen- sind unverbindlich. Konstruktionsverbesserungen sind vorbehalten