

Cesto per meccanismo colonna estraibile.
Basket for extractable column mechanism.

Art. **1852Y**

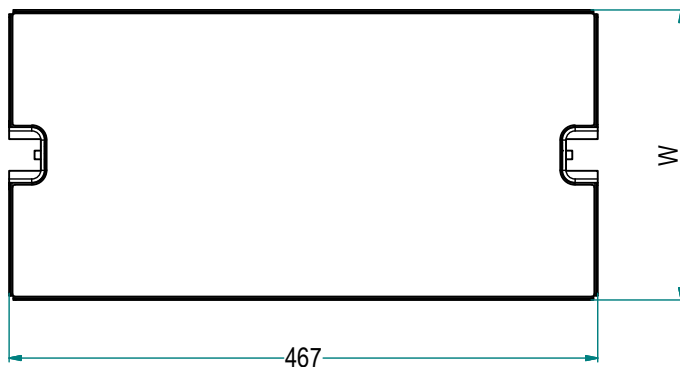
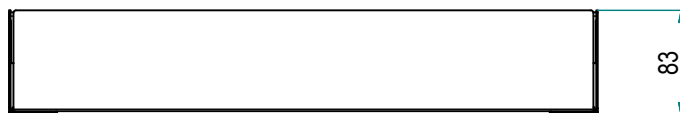
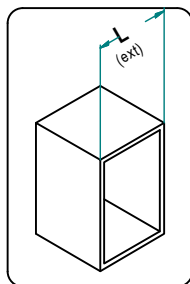
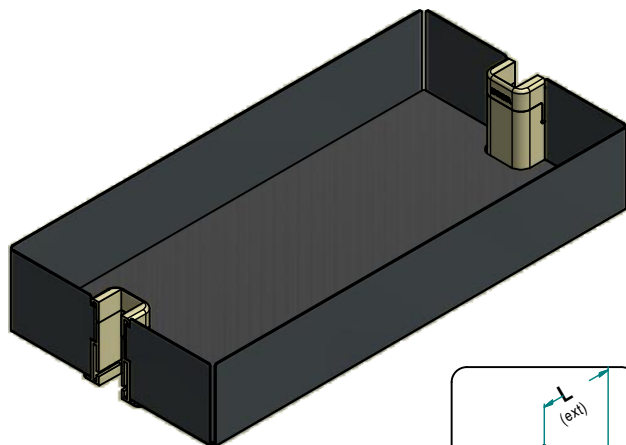

1852Y AS / 30 AR 2

Optional

AS: Anti-Scivolo Tappetino / Anti-Slip Mat

Imballo / Packaging

	Pezzi per scatola Parts in the box
2	2
3	3

**Finitura Cesto / Fondo
Finishing Basket / Panel**

AR: Ardesia RAL 7043 / RAL 7043 Panel

CH: Champagne / Champagne Panel

N: Black Anthracite / RAL 7043 Panel

Larghezza / Width

L [cm]	W [mm]
15	95
20	130
30	230
40	330
45	380
50	430
60	530

**Caratteristiche
Principali**

**Main
Features**

o Struttura in Lamiera Fe360 spessore 1,2mm

o Accessori plastici in Poliammide PA6

o Tappetino Antiscivolo RAL7043

o Verniciato con Polvere Epossidica

o Portata [kg]: 10

o 1,2mm Fe360 Sheet Metal Structure

o Plastics part made in PA6 Polyamide

o RAL7043 Non-Slip Mat

o Painted with epoxy powder

o Capacity [kg]: 10

**Manutenzione
Maintenance**

Pulire con un panno morbido ed asciutto. Evitare l'uso di solventi e/o abrasivi.
Clean with a soft, dry cloth. Avoid using solvents or abrasive.

**Istruzioni d'uso
Use manual**

Consultare le INDICAZIONI DI MONTAGGIO per l'installazione del prodotto.
See ASSEMBLY INSTRUCTIONS of product installation.